

GW22-SY Series Solar Pump Inverter Catalog

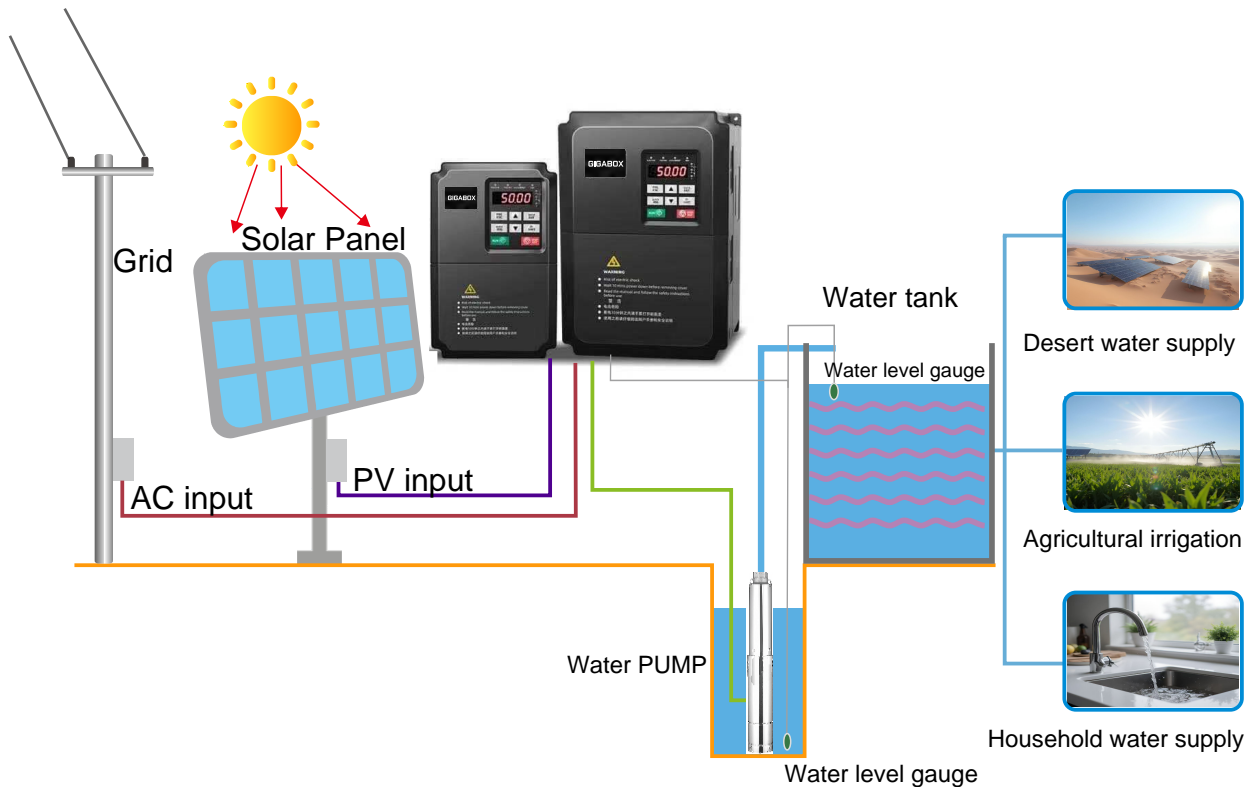

- Start and sleep automatically
- work without care for 24 hours
- Optional configuration of WIFI module
- Maximum power point tracking (MPPT) up to 99%
- Waterless protection (without sensors)
- Optional built-in timing function
- Optional configuration of GPRS module
- AC-DC simultaneous access seamless switching

1 . Rated voltage and current



Model	-SS2	-S2	-2	-4
AC input voltage (V)	220(-15%)~240(+10%) (1PH)		220(-15%)~240 (+10%) (3PH)	380(-15%)~440 (+10%) (3PH)
Max. DC voltage (V)	440	440	440	900
Start-up voltage (V)	200	200	200	300
Lowest working voltage (V)	150	150	150	250
Recommended DC input voltage range (V)	200~400	200~400	200~400	300~750
Recommended MPP voltage (V)	330	330	330	550

Series	Model	Rated output power (Kw)	Rated input current (A)	Rated output current (A)
-SS2 (0.4-2.2 Kw)	0R4G-SS2-PV	0.4	6.5	4.2
	0R7G-SS2-PV	0.75	9.3	7.2
	1R5G-SS2-PV	1.5	15.7	10.2
-S2 (0.4-2.2 kW)	2R2G-SS2-PV	2.2	24	14
	0R4G-S2-PV	0.4	6.5	2.5
	0R7G-S2-PV	0.75	9.3	4.2
-2 (4-7.5kW)	1R5G-S2-PV	1.5	15.7	7.5
	2R2G-S2-PV	2.2	24	10
	004G-2-PV	4	17	16
-4 (0.75-110kW)	5R5G-2-PV	5.5	25	20
	7R5G-2-PV	7.5	33	30
	0R7G-4-PV	0.75	3.4	2.5
	1R5G-4-PV	1.5	5.0	4.2
	2R2G-4-PV	2.2	5.8	5.5
	004G-4-PV	4.0	13.5	9.5
	5R5G-4-PV	5.5	19.5	14
	7R5G-4-PV	7.5	25	18.5
	011G-4-PV	11	32	25
	015G-4-PV	15	40	32
	018G-4-PV	18.5	47	38
	022G-4-PV	22	51	45
030G-4-PV	30	70	60	
037G-4-PV	37	80	75	

2 . Wiring diagram

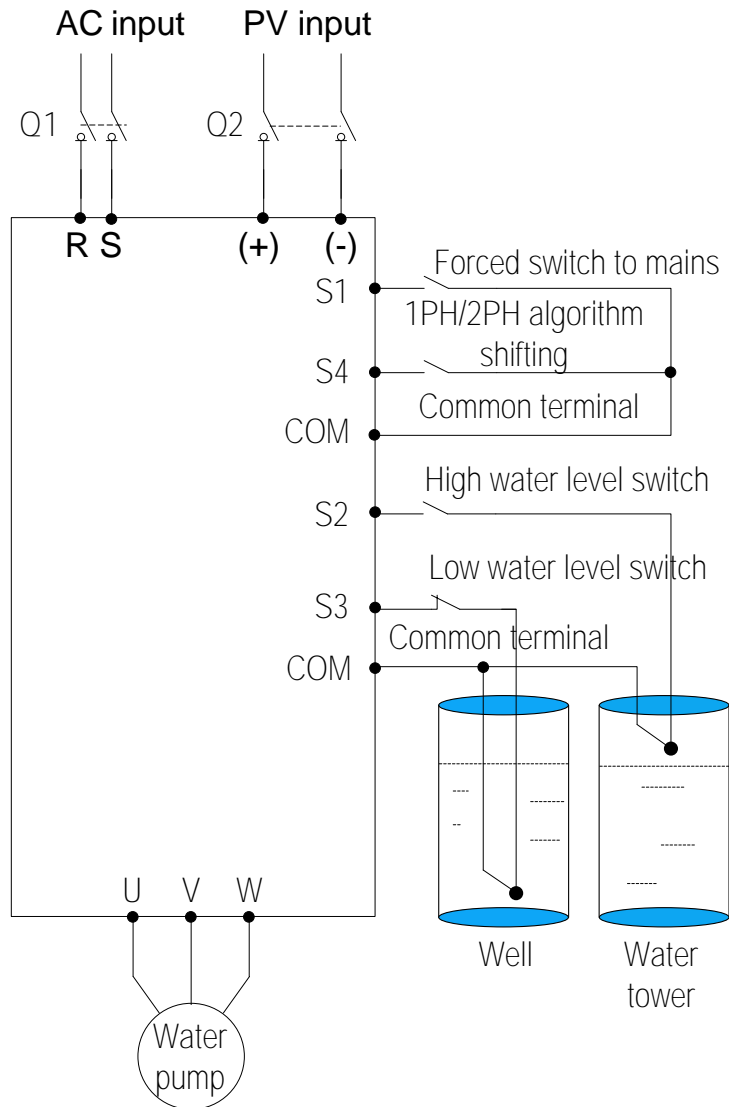

- ✧ The DC breaker Q1 must be installed as the protection switch for PV input.
- ✧ In parallel connection, the combination box special for PV must be used.
- ✧ When the distance between the PV input component and VFD exceeds 10 meters, type-II surge protection devices must be configured at the DC side.
- ✧ When the distance between the pump and VFD exceeds 50 meters, it is recommended to configure output reactors. See appendix A.4 for the output reactor model selection.
- ✧ The VFD automatically runs after being powered on. If parameters need to be set, follow the parameter setting instructions in chapter 5.
- ✧ Before connecting the braking resistor cable remove the yellow labels of (+), and (-) from the terminal blocks. Otherwise, poor connection may occur.

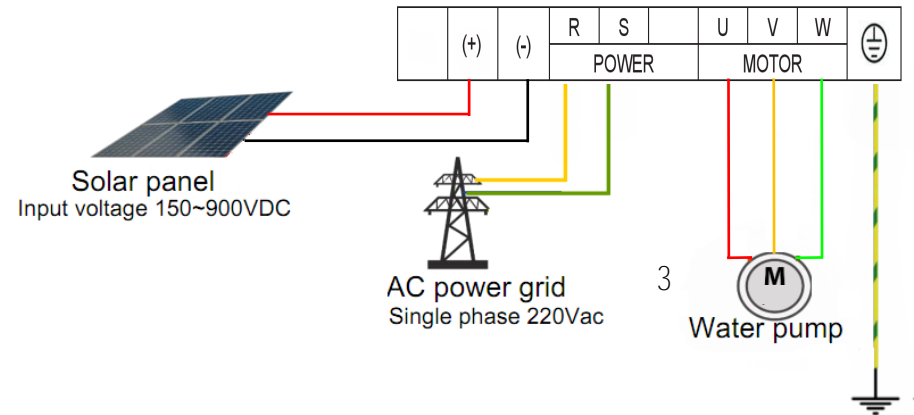



3. Technical Specifications

Input voltage range	80V to 450VDC input, 3PH 110VAC output, 1S model 150V to 450VDC input, 3PH 220VAC output, 2S/2T model 250V to 800/900VDC input, 3PH 380/440/480VAC output
Recommended input voltage (Voc and Vmp)	Voc 180VDC, Vmp 155VDC for 1S model & 110VAC pumps Voc 370VDC, Vmp 310VDC for 2T model & 220VAC pumps Voc 650VDC, Vmp 540VDC for 4T model & 380VAC pumps
Motor type	Control for permanent magnet servo motor and asynchronous motor pumps.
Input power	DC power from solar arrays or AC grid power
Maximum DC power input	450VDC for 220AC output & 800/900VDC for 380V AC output, (900V needs remark)
Rated output voltage	Single phase 220V, 3-phase 220V/380V/480V
Output frequency range	0~50/60Hz
MPPT efficiency	99.6%,
Ambient temperature range	G-type inverter with submersible pumps, and P type for general pumps.
Solar pump control special performance	MPPT (maximum power point tracking), CVT (constant voltage tracking), auto/manual operation, dry run protection, low stop frequency protection, minimum power input, motor maximum current protection, flow calculating, energy generated calculating.
Protection function	Phase loss protection, phase short circuit protection , ground to phase circuit protection , input and output short circuit protection. Stall protection
Protection degree	IP20
Running mode	MPPT , CVT, variable frequency mode
Altitude	Below 1000m; above 1000m, derated 1% for every additional 100m.
Standard	CCC, CE, IEC

4 . Software ware design

Feature >>



Effective protection function, including PV over-voltage protection, over-current protection, auto derating against over-temperature, etc.



Advanced MPPT algorithms: Solar maximum power point tracking efficiency reaches 99%.



Support GPRS module, which can remote monitor the controller by using the APP.



The solar pump controller automatically start or sleep only after being connected to solar panel without any parameter setting.



Model(=2.2kW) can be configured with the boost module, which can make the pump work in low voltage and reduce the cost by decreasing the numbers of solar panel.



Drinking Water

Irrigation

Responsible Leisure

Solar Capture

