

Warning Symbols

About This Guide

Unboxing

Check Before Installation

In the Solarbank Box

Optional Accessories

Anker SOLIX BP2700 Expansion Battery

Anker SOLIX Smart Meter

Anker SOLIX Smart Plug

Product Overview

At a Glance

Button Controls

LED Guide

Pre-Installation

Select an Installation Site

Environment Requirements

Stacking Requirements

Equipment Dimensions

Tools Not Supplied

Installation

Precautions

Step 1. Place the Bottom Expansion Battery

Step 2. Remove Rubber Plugs

Step 3. Stack with Solarbank at the Top

Step 4. Install the Wall Mount Kit

Step 5. Install the Interlocking Kit

Electrical Connections

Precautions

Connect to the Ground

Connect to the Grid

Connect to Your Device

Connect to PV Modules

Direct Connection (Up to 4 PV Modules)

Parallel Connection (Up to 8 PV Modules)

(Optional) Install the Smart Meter

(Optional) Install the Smart Plug

Device Setup

Power On / Off

Confirm Networking Status

Use the Anker App

Download the Anker App

Sign Up / Sign In

Connect to the Network

Add Home Devices

Upgrade Firmware

Customize Power Mode

Access Mode Selection

Smart Mode

Self-Consumption Mode

Custom Mode

Smart Plug Mode

Schedule Mode

Manual Backup Power

Adding an Expansion Battery

Precautions

Step 1. Disassemble the System

Step 2. Mount the Expansion Battery

Step 3. Reassemble the System

FAQ

Specifications

Anker SOLIX Solarbank 3 E2700 Pro

Anker SOLIX BP2700 Expansion Battery

Warning Symbols



This symbol signifies the presence of dangerous high voltage and risk of electric shock.



This symbol indicates it will take 15 minutes to de-energize the system.
WARNING (For service personnel): To reduce the risk of electric shock or personal injury, do not touch or disassemble any components for at least 15 minutes after the equipment has been turned off or disconnected.



Refer to the operation instructions.

About This Guide

This guide describes **Anker SOLIX Solarbank 3 E2700 Pro** in terms of unboxing, product overview, installation, electrical connections, button and light explanation, customer service, and safety guidelines.

- One **Anker SOLIX Solarbank 3 E2700 Pro** can support up to 5 **Anker SOLIX BP2700 Expansion Batteries**.
- **Anker SOLIX Solarbank 3 E2700 Pro** can be used with Anker SOLIX Smart Meter, Anker SOLIX Smart Plug and some third-party devices, which is updated periodically.

Unboxing

Check Before Installation

Inspect the Outer Packaging

Before unpacking the equipment, check the outer packaging for damage, such as holes and cracks, and review the equipment model number. If any damage is found or the model is not what you requested, do not unpack the equipment and contact Anker customer service as soon as possible.

Verify Deliverables

After unpacking the equipment, check that the deliverables are intact and complete, and free from any obvious damage. If any item is missing or damaged, contact Anker customer service.

In the Solarbank Box

Model: A17C53Z1, A17C53Z1-20

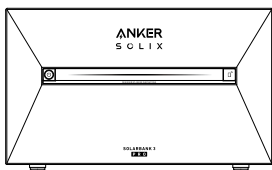

Anker SOLIX Solarbank
3 E2700 Pro

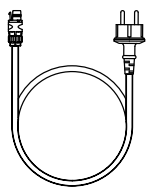

AC Cable with Schuko
Plug (3 m)

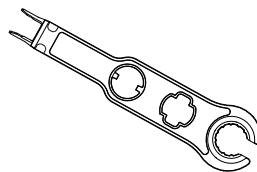

Wrench for Removing
PV Connectors



Documents

Optional Accessories

The following accessories must be ordered separately.

Anker SOLIX BP2700 Expansion Battery

Model: A17C53Z1-85

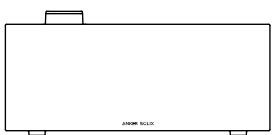

Anker SOLIX BP2700
Expansion Battery

Interlocking Kit



Fixed Bracket
×2



Screw (M5 10 mm)
×2



Documents

Wall Mount Kit



L-Shape Wall Mount
Fitting
×2

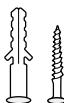

Expansion Screw
(M5 60 mm)
×2



Screw (M5 10 mm)
×2

Anker SOLIX Smart Meter

Model: A17X7

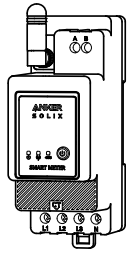

Anker SOLIX Smart Meter

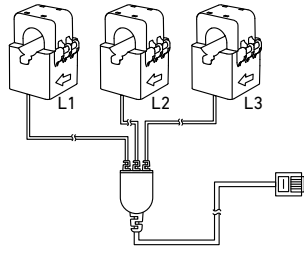

Current Transformers

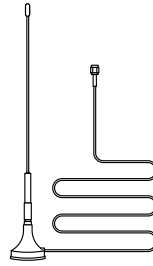

Extension Antenna

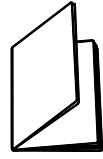

Important Safety Instructions

Anker SOLIX Smart Plug

Model: A17X8

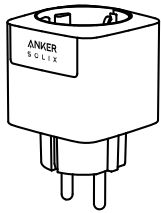

Anker SOLIX Smart Plug

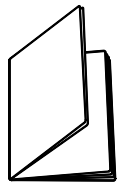

Important Safety Instructions

Product Overview

At a Glance

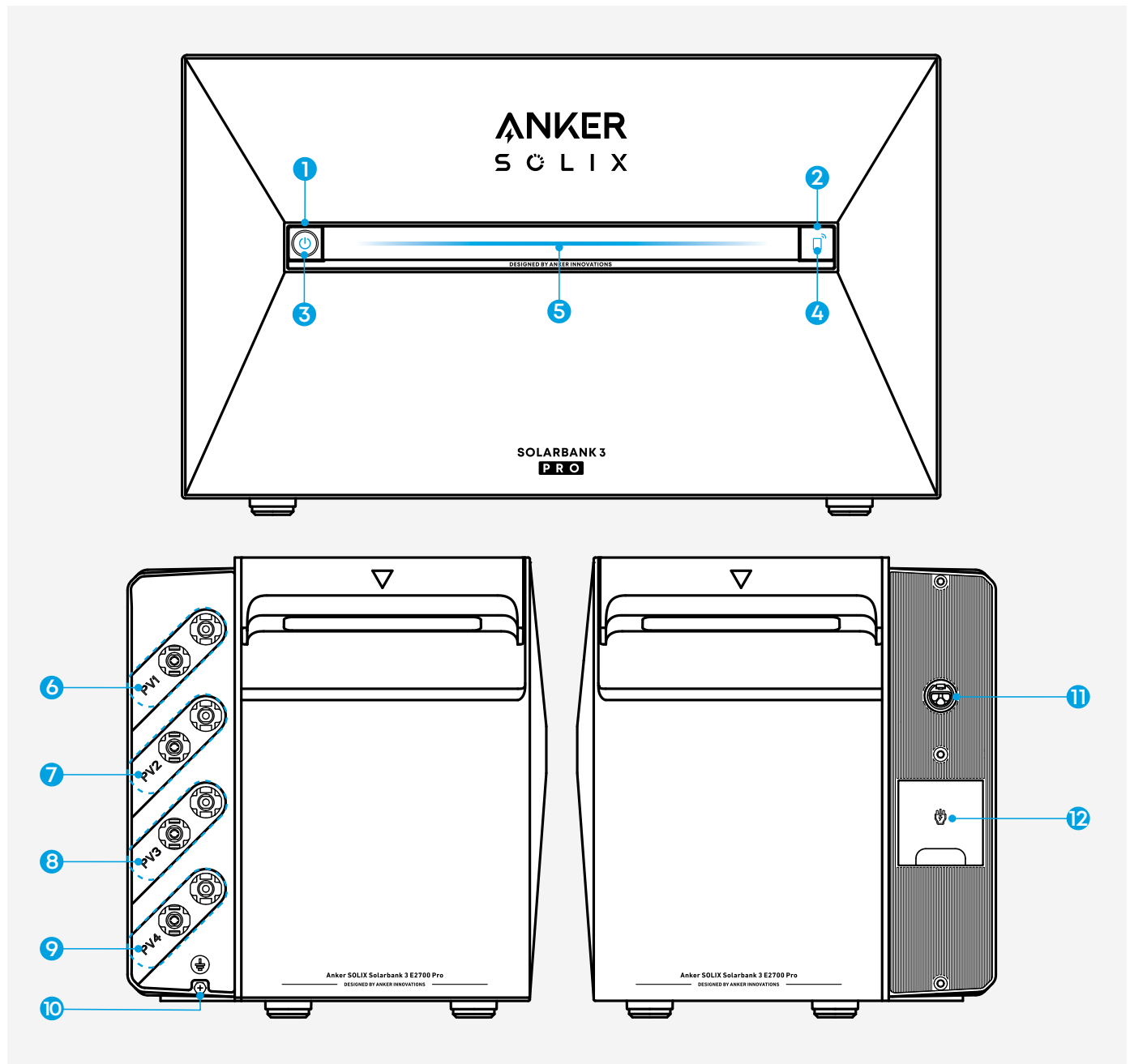





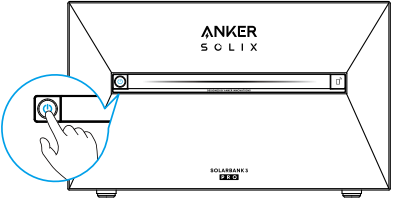
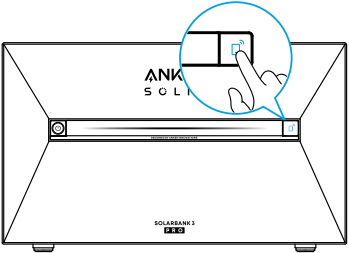
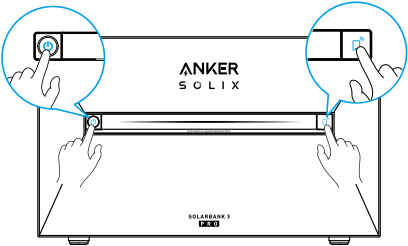

- 1 Power Button
- 2 IoT Button
- 3 Power Status LED
- 4 IoT Status LED
- 5 Working Status LED
- 6 PV Connector Ports for PV Input 1
- 7 PV Connector Ports for PV Input 2
- 8 PV Connector Ports for PV Input 3
- 9 PV Connector Ports for PV Input 4
- 10 Ground Screw Hole
- 11 Grid-Tied Terminal
- 12 Backup Terminal

Button Controls

Button	Action	Function
	Press for 3 seconds.	Turn Solarbank on / off.
	Press once (when Solarbank is on).	Check current battery level.
	Press once.	Enable Internet connection.
	Press for 3 seconds.	Disable Internet connection.
	Press for 7 seconds.	Reset Bluetooth and Wi-Fi.
	Simultaneously press for 9 seconds.	Reset Solarbank.

LED Guide

Button	Description	Status
	Solid blue	Powered on
	Off	Powered off
	Flashing red	Malfunction / warning
	Flashing blue	Internet connection enabled / reset
	Off	Internet connection disabled

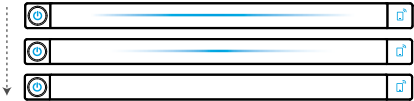
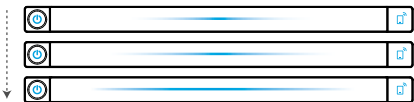
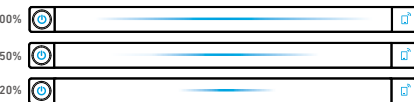
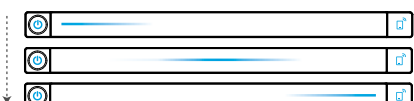
Light Bar	Description	Status
	The center LED illuminates toward both sides.	Powered on
	The lights on both sides fade toward the center.	Powered off
	The LED illuminates toward both sides, and then cycles again.	Recharging
	The light bar changes according to battery level.	Battery level
	The light runs from left to right.	Upgrading firmware

Pre-Installation

Select an Installation Site

Environment Requirements

- Do not place the modules near an area exposed to direct sunlight, fire, or explosive materials.
- Ensure the site is protected from potential hazards such as floods.
- The maximum operating altitude is 4,000 m.

Stacking Requirements

Select the appropriate installation space according to the equipment configuration to be installed. Reserve sufficient space for heat dissipation and safety isolation.

Anker SOLIX Solarbank 3 E2700 Pro			
Model	A17C53Z1, A17C53Z1-20	A17C53Z1-1, A17C53Z1-20-1	A17C53Z1-2, A17C53Z1-20-2
Expansion Battery	0	×1	×2
Energy	2,688Wh	5,376Wh	8,064Wh

Rated Charging Power	1,800W	3,600W	3,600W	
Rated Discharging Power	1,200W	1,200W	1,200W	
Anker SOLIX Solarbank 3 E2700 Pro				
	Model	A17C53Z1-3, A17C53Z1-20-3	A17C53Z1-4, A17C53Z1-20-4	A17C53Z1-5, A17C53Z1-20-5
	Expansion Battery	×3	×4	×5
	Energy	10,752Wh	13,440Wh	16,128Wh
Rated Charging Power	3,600W	3,600W	3,600W	
Rated Discharging Power	1,200W	1,200W	1,200W	

Equipment Dimensions

Solarbank: 460 (W) × 254 (D) × 279 (H) mm

Expansion Battery: 460 (W) × 233 (D) × 217.5 (H) mm

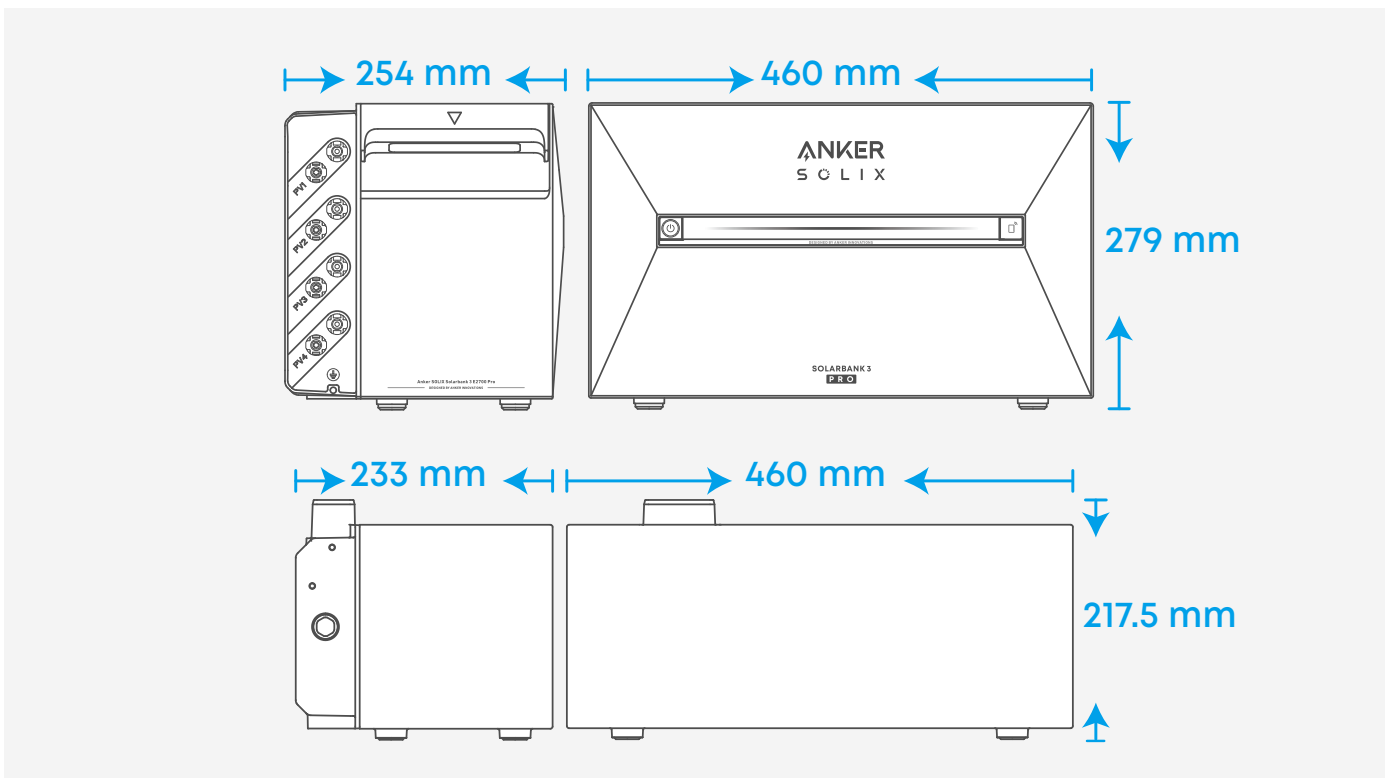

Tools Not Supplied

The following tools are not included in this package. Please make sure they are ready before installation and electrical connections.

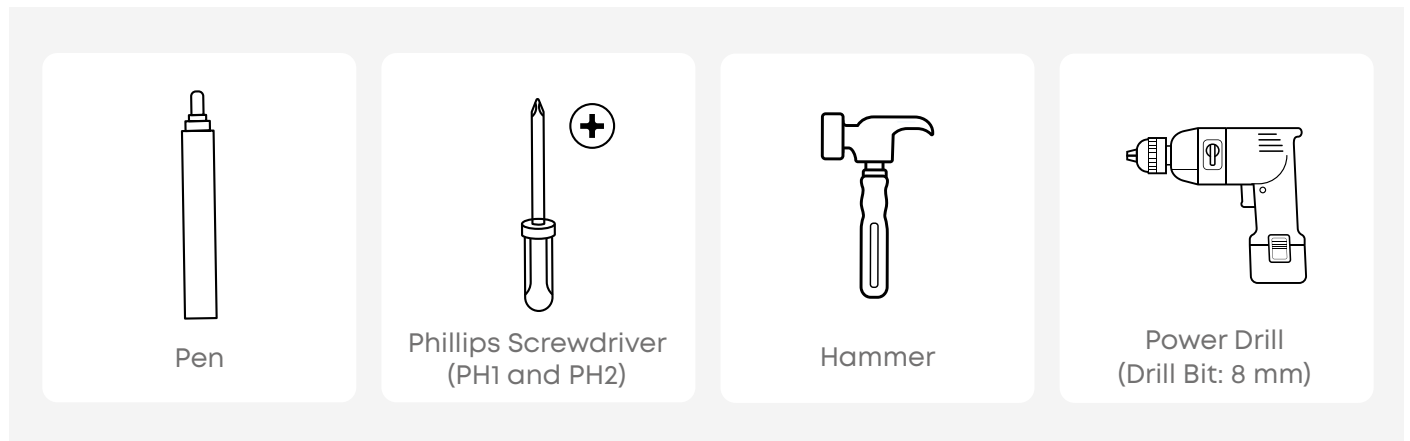

Installation

Precautions

- The following steps describe how to install one Solarbank and two expansion batteries as an example.
- Ensure Solarbank is off during installation.

Step 1. Place the Bottom Expansion Battery

- Ensure the heat sink on the back of the expansion battery faces the wall.
- Position within Wi-Fi coverage for Solarbank to connect to the network.
- Keep 18 to 47 mm away from the wall.

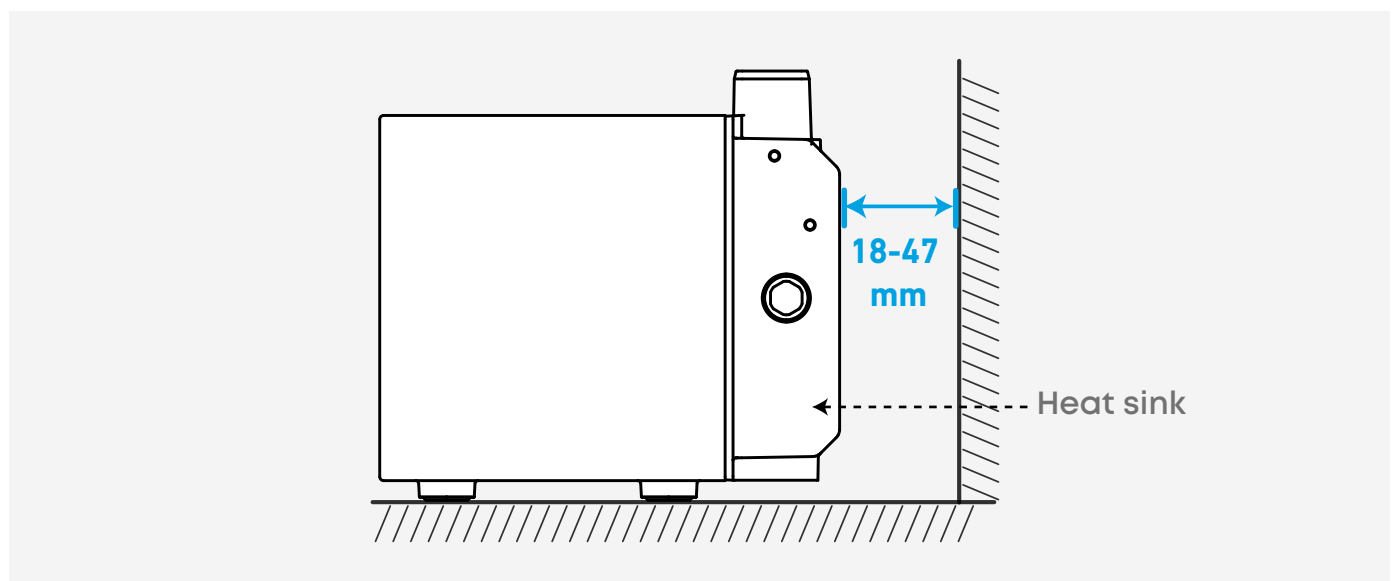

Step 2. Remove Rubber Plugs

Unfasten screws (if applicable) and remove the rubber plugs.

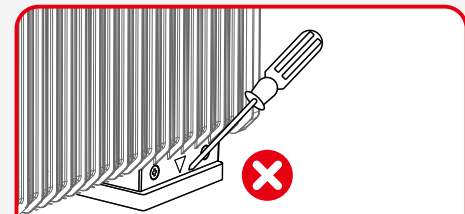
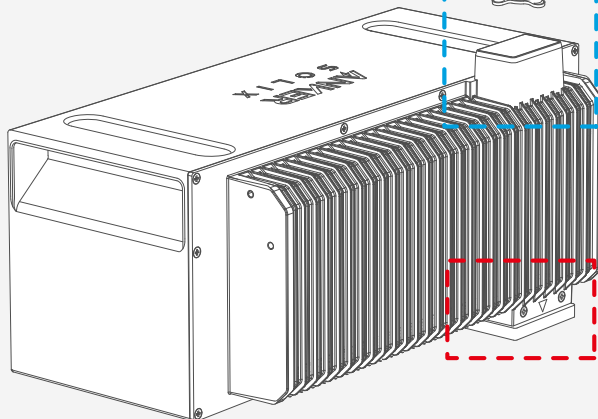
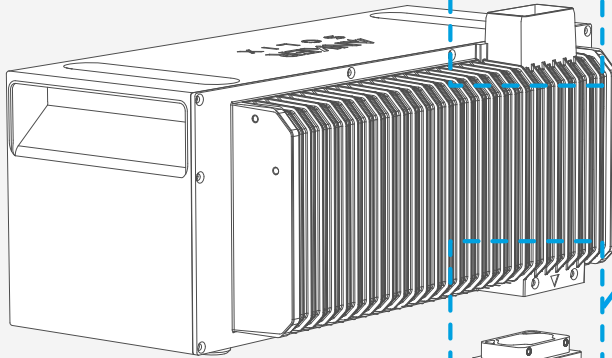
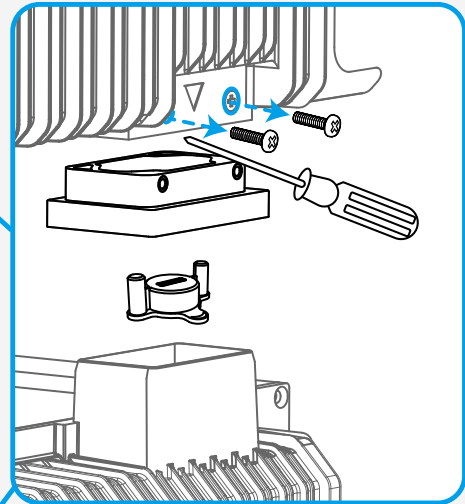
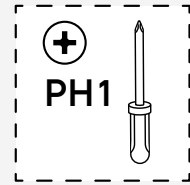
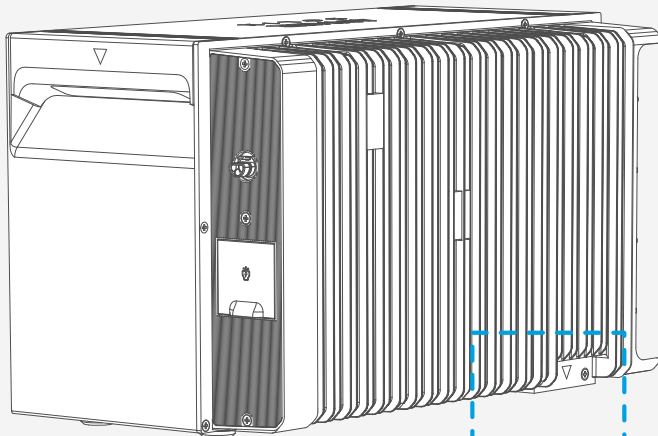

When installing the bottom battery pack or only one Solarbank, do not remove the bottom rubber plug to avoid water damage to the equipment.

Step 3. Stack with Solarbank at the Top

Stack expansion batteries in sequence with Solarbank at the top by inserting the two corresponding ports into each other.

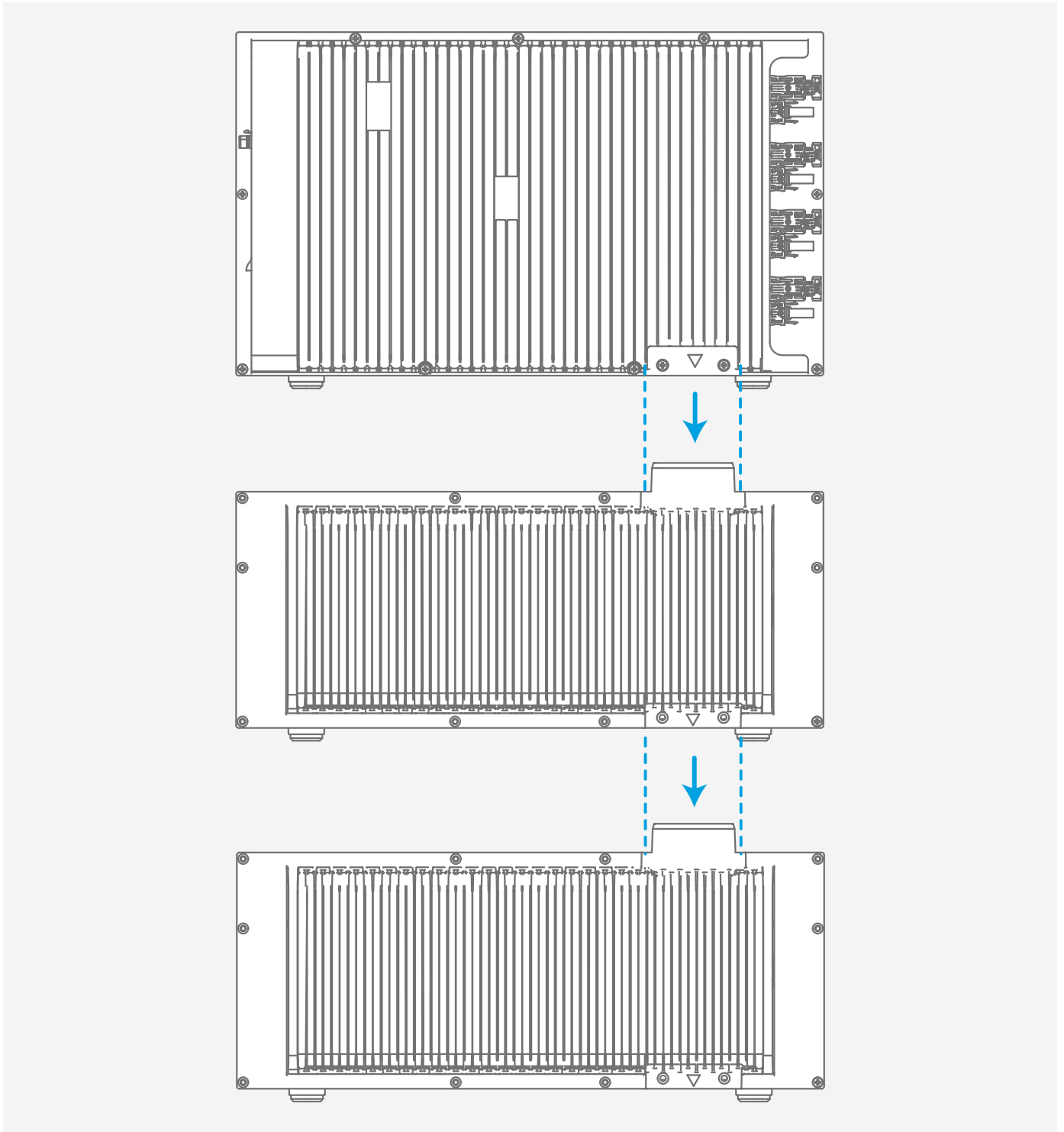

Step 4. Install the Wall Mount Kit

Attach the L-Shape wall mount fittings to both sides of the first expansion battery under Solarbank.

Extra fittings are not needed for other expansion batteries.

① Install a fitting on one side by partially tightening the short screw.

The fitting can be mounted on the front or the back.

② Mark a pilot hole.

③ Rotate the fitting down.

④ Drill the marked hole.

⑤ Insert the anchor.

⑥ Rotate the fitting back up.

⑦ Tighten the long screw.

⑧ Tighten the short screw.

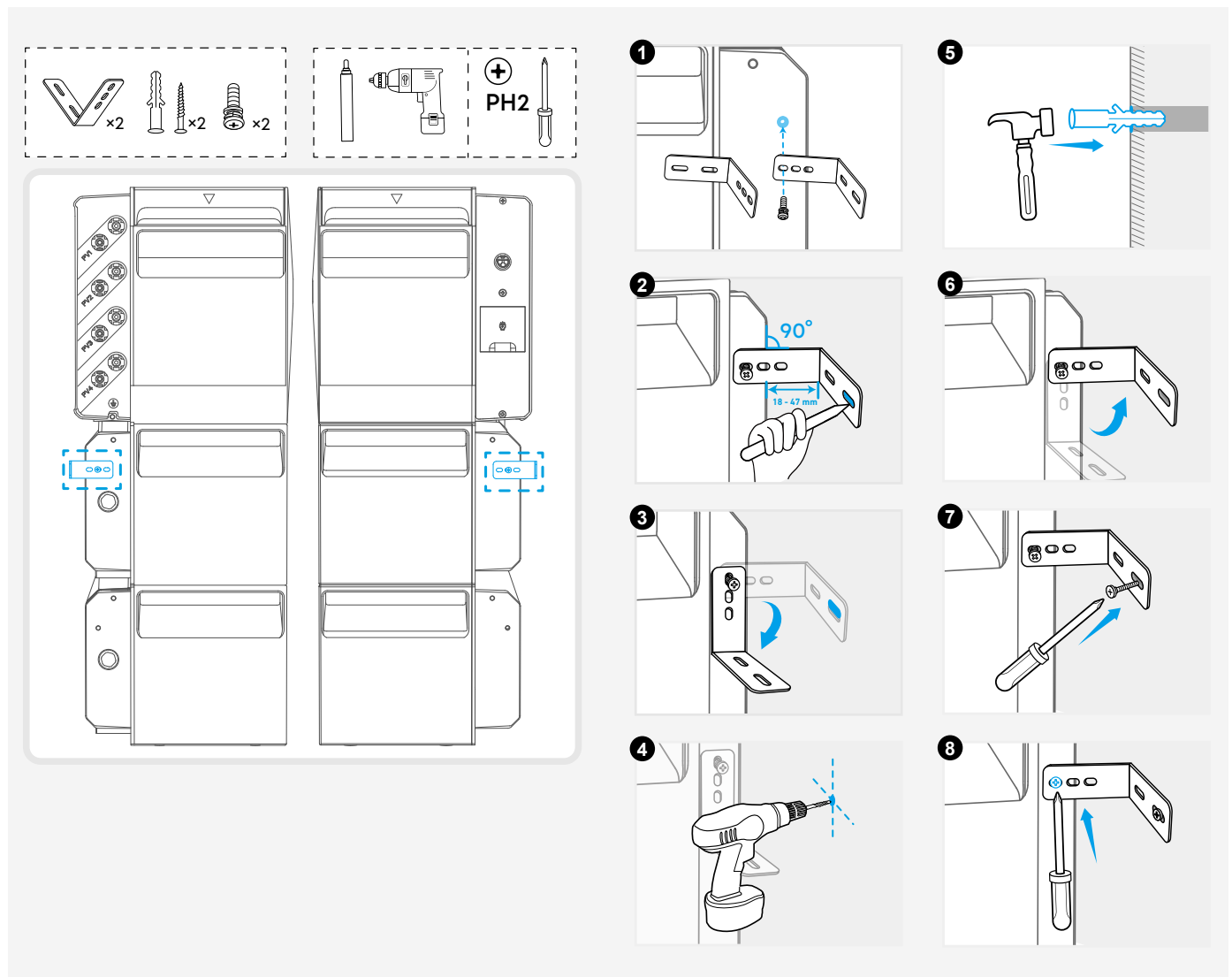

Step 5. Install the Interlocking Kit

Attach the fixed brackets to both sides of each expansion battery.

- 1 Snap the fixed bracket in place.
- 2 Tighten the screw.

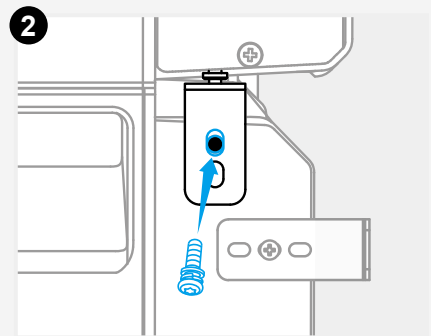
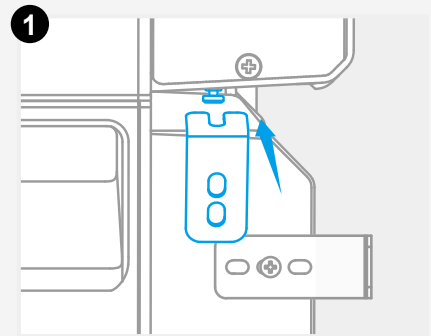
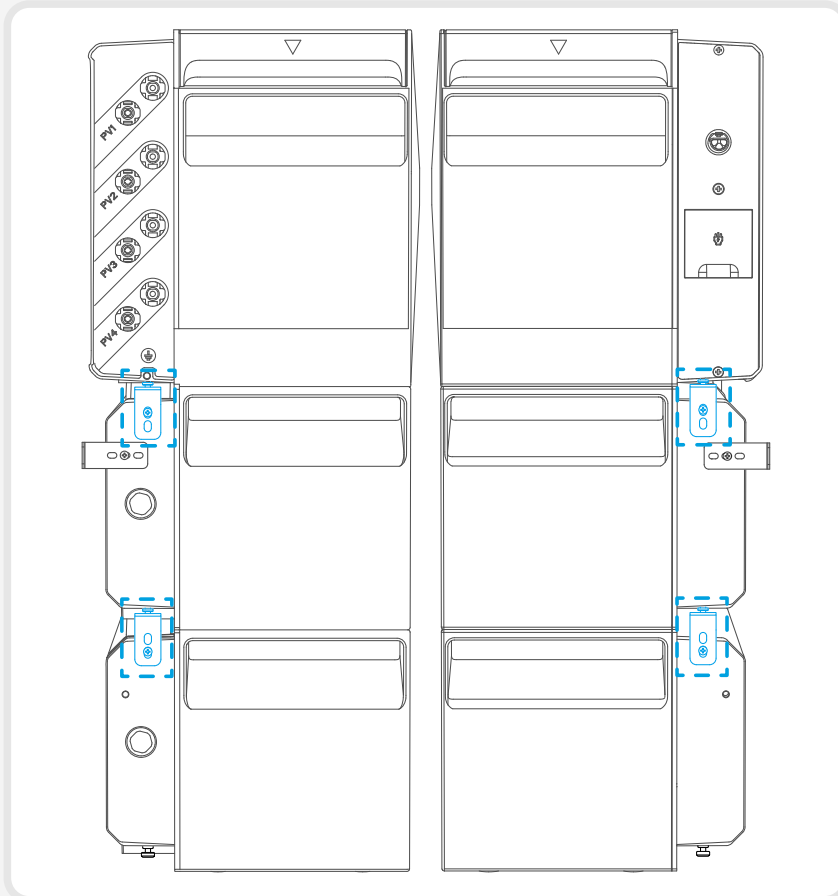
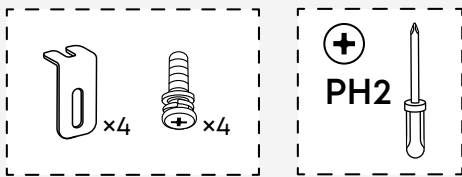

Electrical Connections

Precautions

- Ensure Solarbank is off during wiring.
- Do not use or turn on Solarbank after it has come into contact with water.

Connect to the Ground



Solarbank must be connected to the external ground point, otherwise there is a risk of electric shock.

The following tools and supplies are not included in the package. Ensure that you have them ready before proceeding with the electrical connections.

Required supplies	Specifications
GND cable	1 mm ² , yellow/green
Ring terminal	Suitable for the 1 mm ² GND cable and the M5 screw
Heat shrink tubing	Caliber: 8 mm Length: 25 mm
Heat gun	/
Phillips screwdriver	PH2

To connect Solarbank to the external ground point, follow the steps below.

- 1 Strip the insulation layer of the GND cable.
- 2 Insert a heat shrink tubing and a ring terminal into the GND cable.
- 3 Crimp the ring terminal onto the GND cable using a crimper.
- 4 Wrap the wire crimping area with the heat shrink tubing using a heat gun.
- 5 Loosen the pre-installed screw and use it to secure the GND cable.

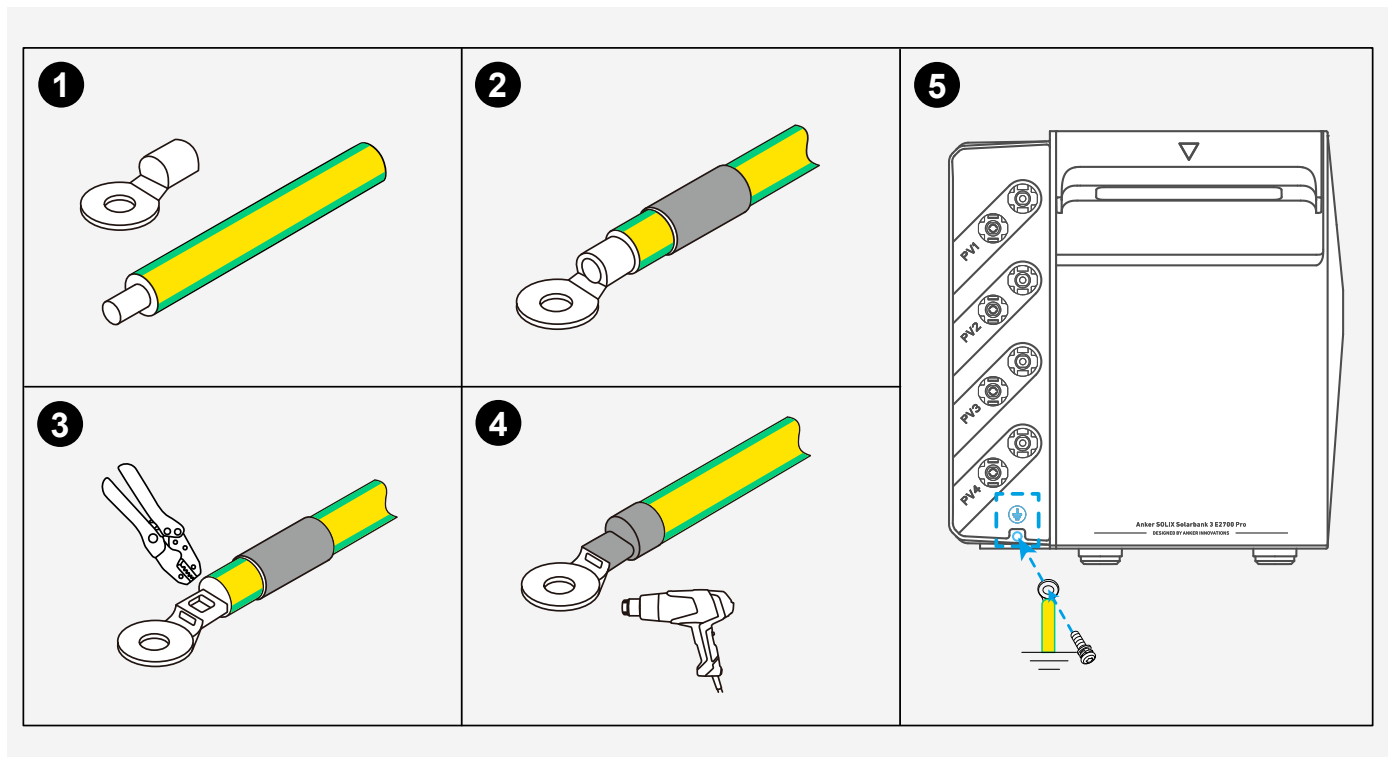

Connect to the Grid

Connect Solarbank to a home outlet using the included AC cable with Schuko plug (3 m).

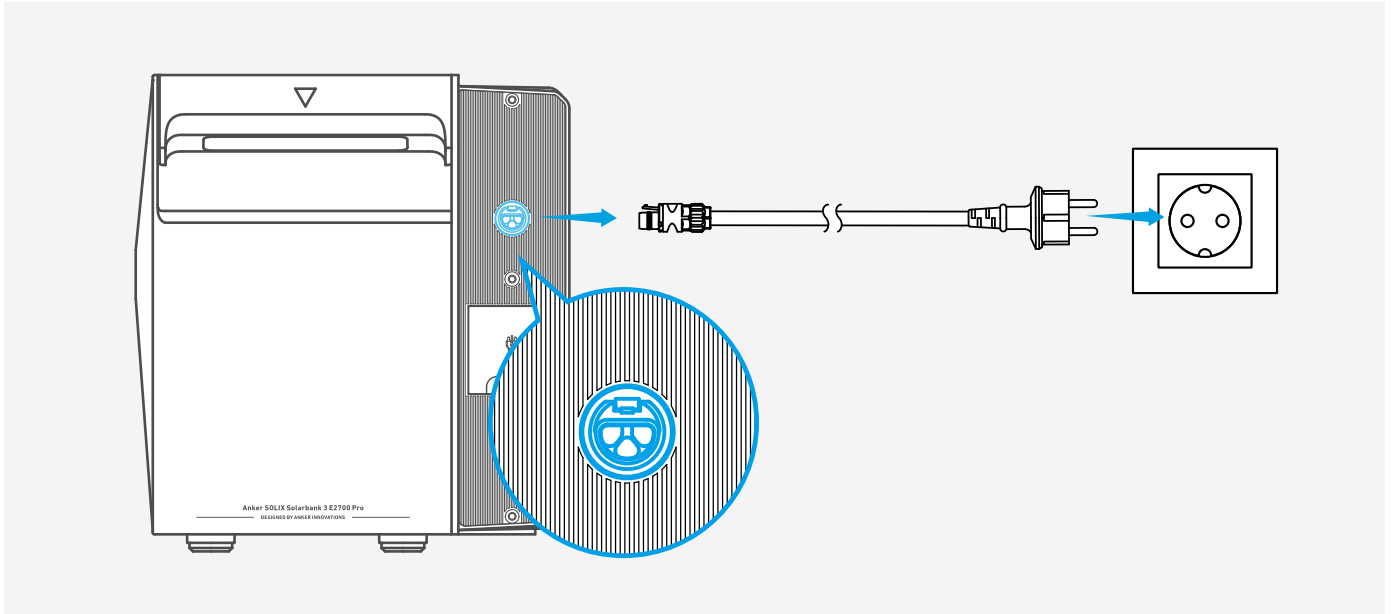

Connect to Your Device

Power your device directly using the backup port if needed.

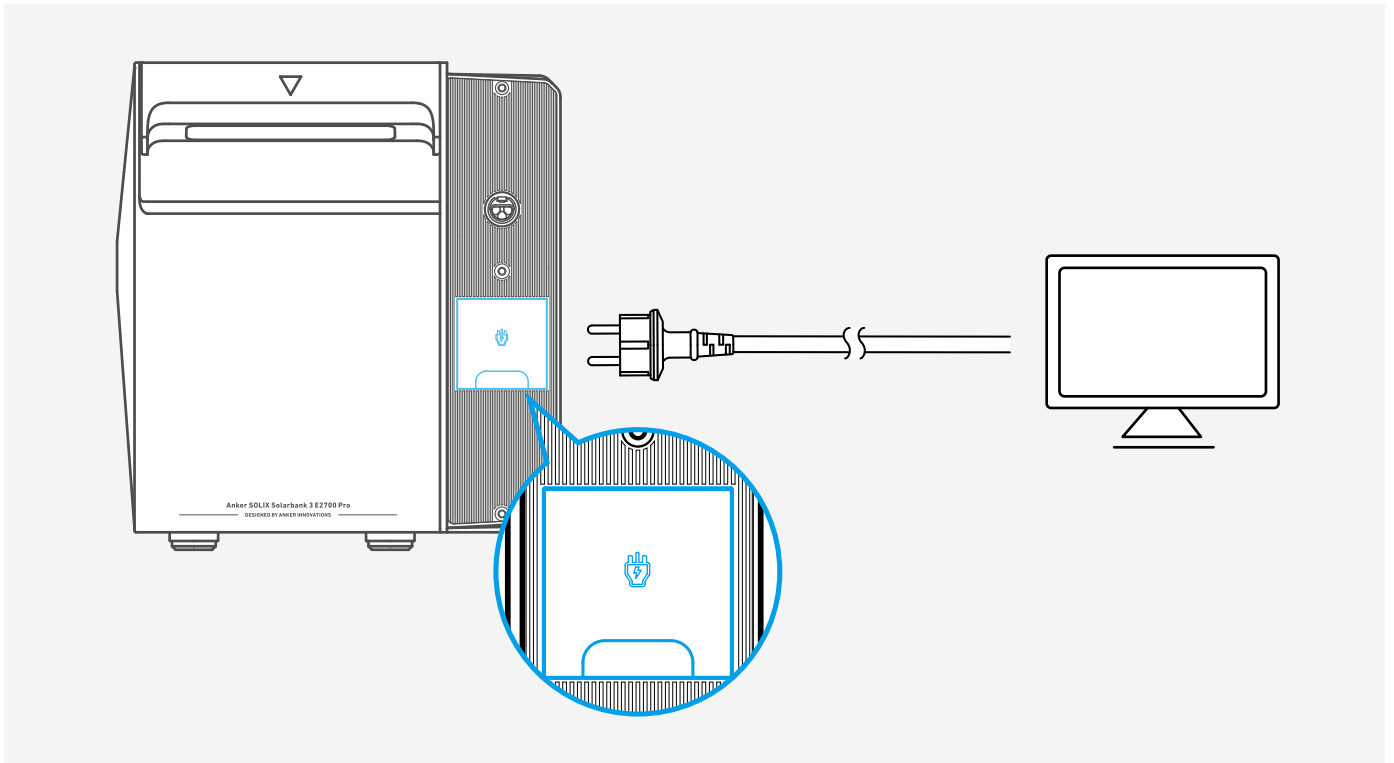

Connect to PV Modules

- Ensure that unused PV ports on Solarbank are sealed with waterproof caps.
- When connecting PV modules in parallel, please check the specifications of the PV modules and ensure that the total short-circuit current does not exceed 40A.



- Never connect two or more PV modules in series because this causes the input voltage to exceed 60V and will damage the equipment.
- It is recommended to use PV cables of 3 m or less. Cables exceeding 3 m in length may interfere with certain electronic devices.

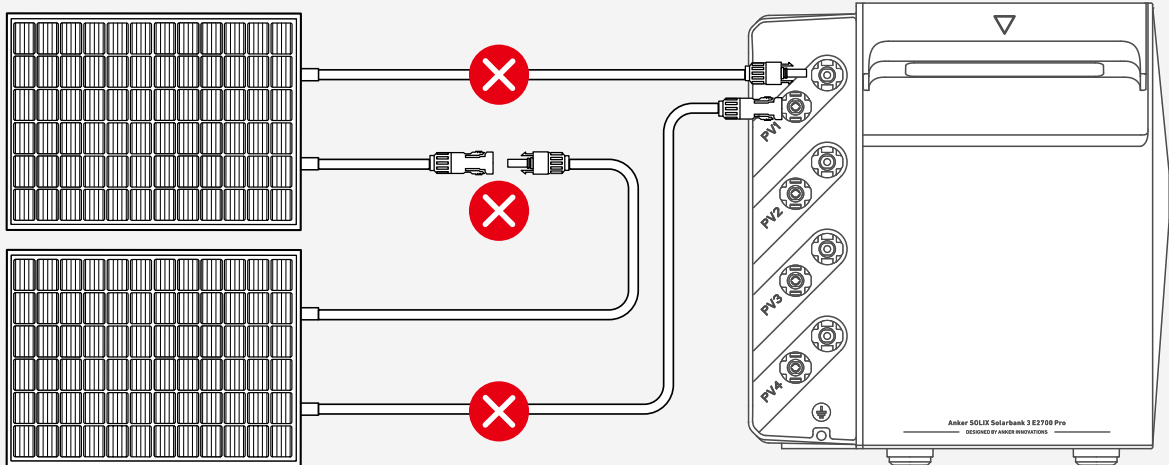

Never connect the same set of PV connectors to different sets of PV input ports. For instance, connecting the positive connector of PV Module 1 to the negative PV2 input port of Solarbank is prohibited.

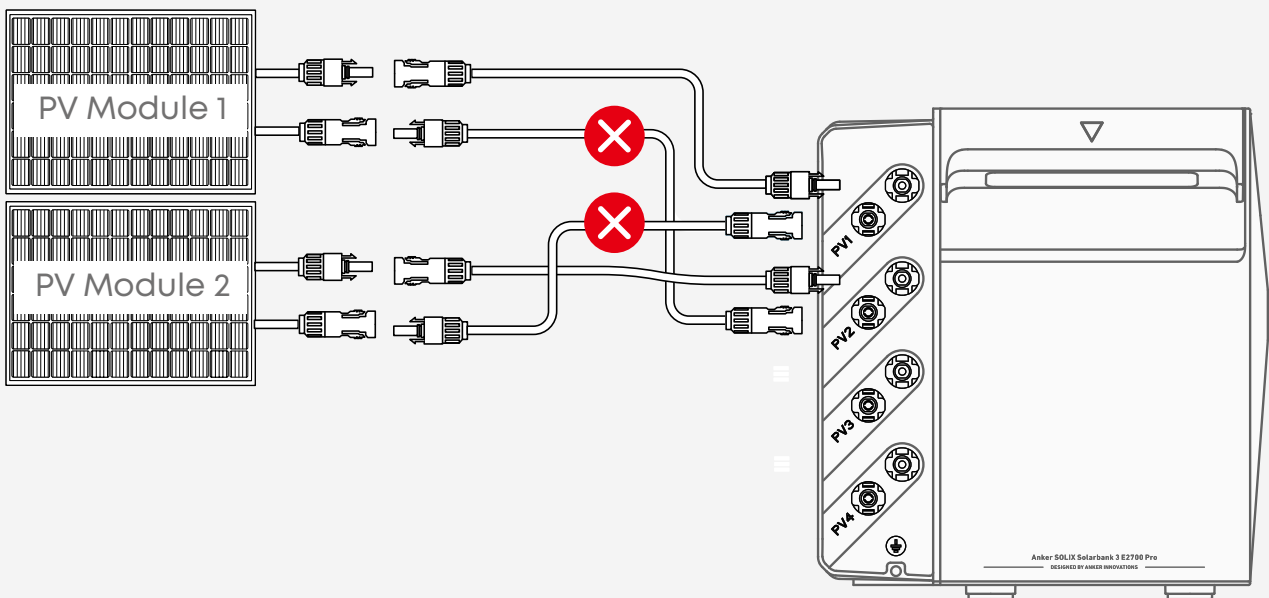

Direct Connection (Up to 4 PV Modules)

Connect each PV module directly to the same set of PV input ports. Use Anker SOLIX Solar Panel Extension Cable (sold separately) to extend the reach if needed.

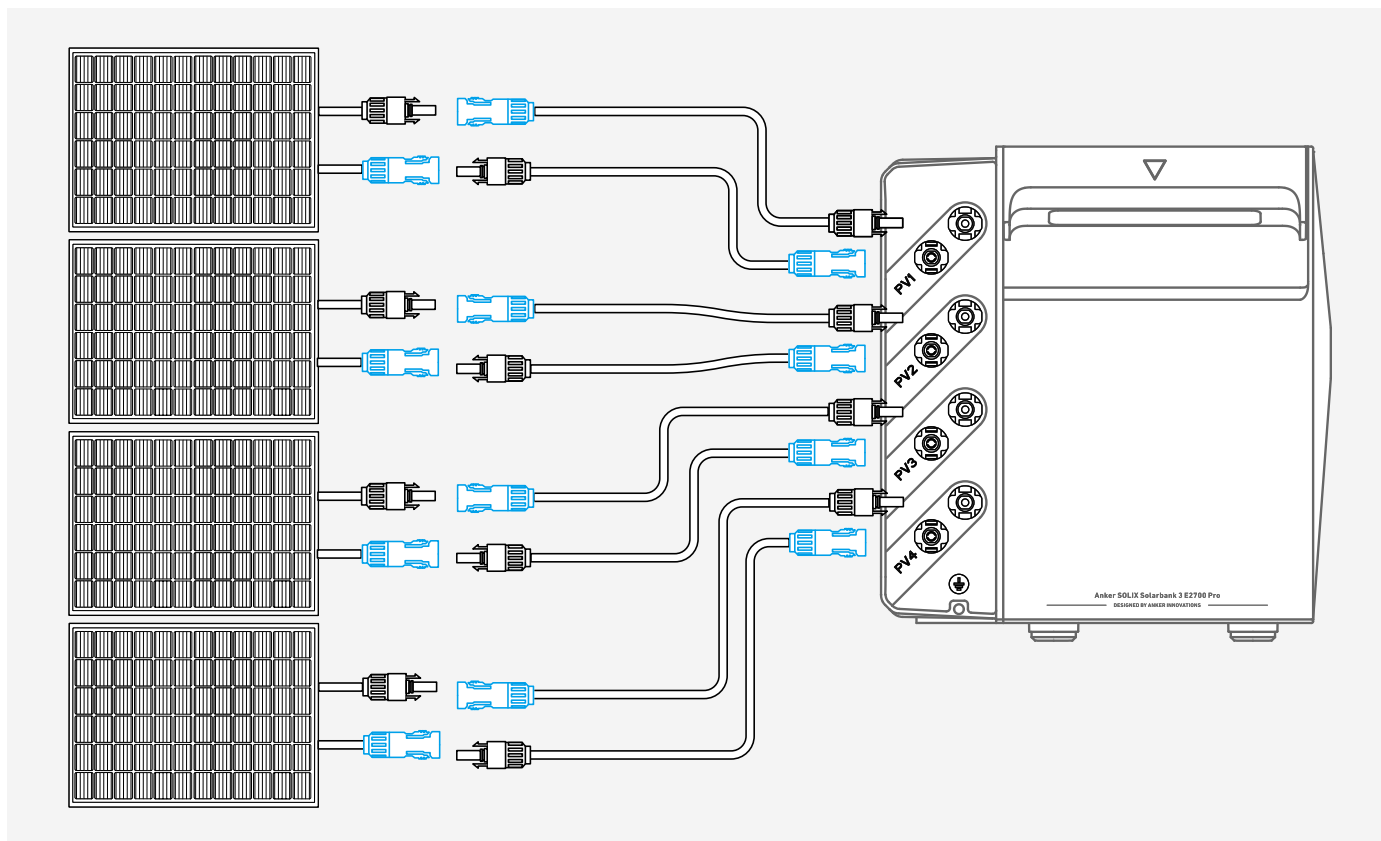

Parallel Connection (Up to 8 PV Modules)

Connect every two PV modules to the same set of PV input ports. Use Anker SOLIX Y Solar Connection Cable (sold separately) for this setup.

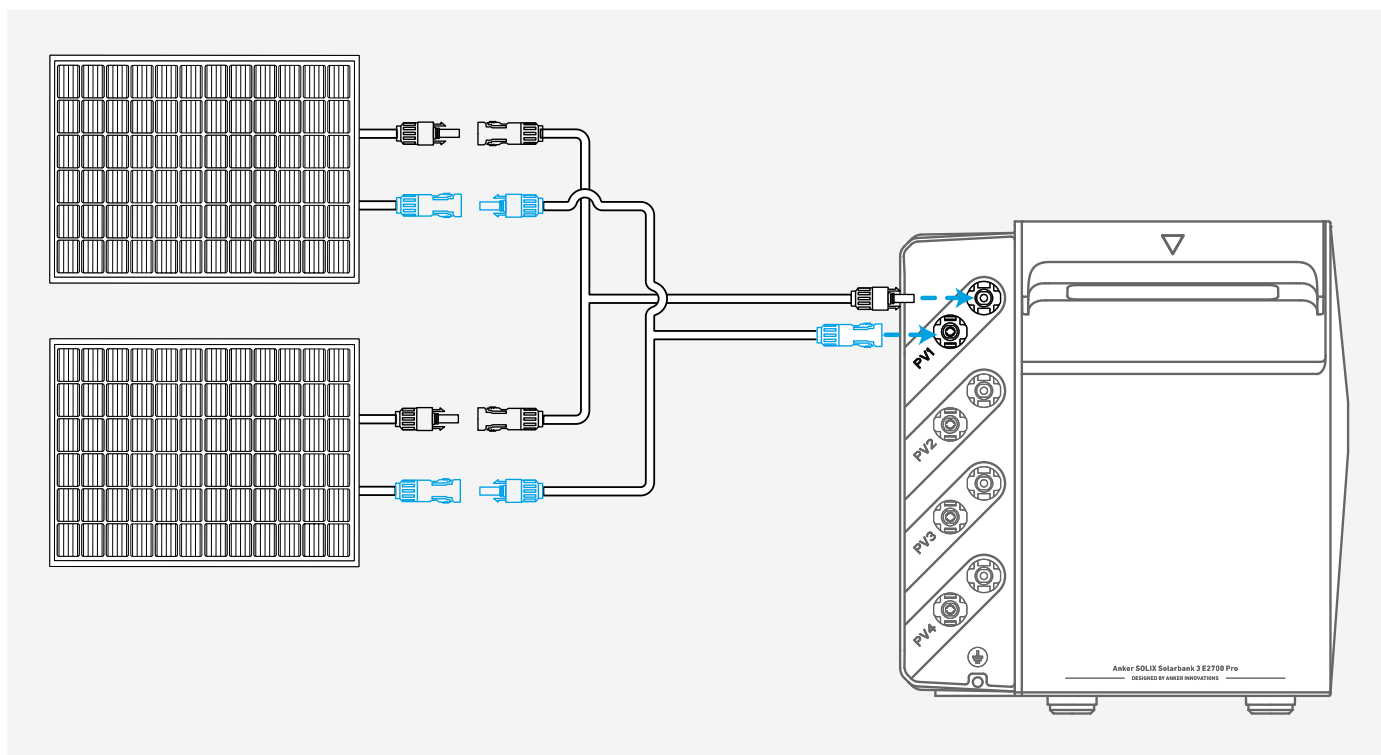

💡 Third-Party Solar Cable Requirements

When using third-party solar cables with your Solarbank, ensure that each cable meets the following specifications.

Current	Conductor Cross-Sectional Area
$\leq 25\text{A}$	4 mm^2
25A to 35A	6 mm^2

Example: The figure below shows solar cable specifications for a PV module with 16A DC output per port.

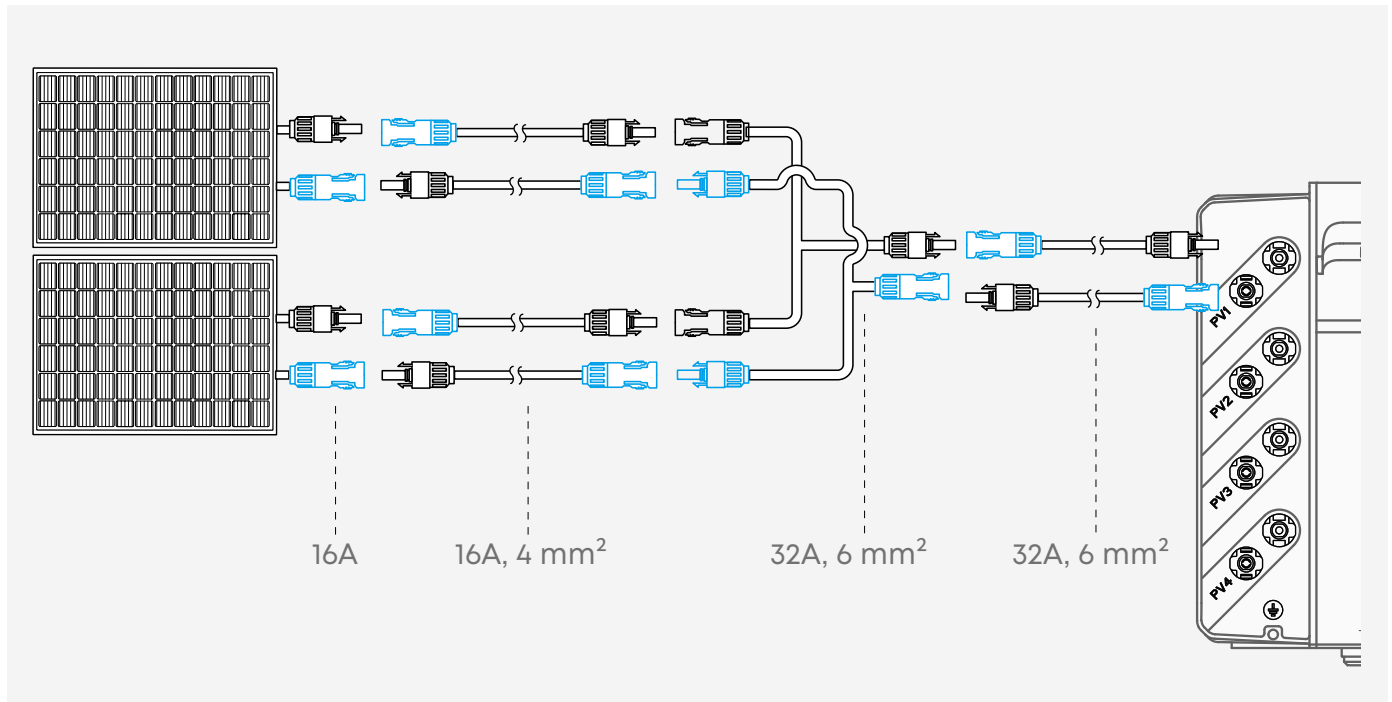

💡 To disconnect the PV connectors, use the included wrench.

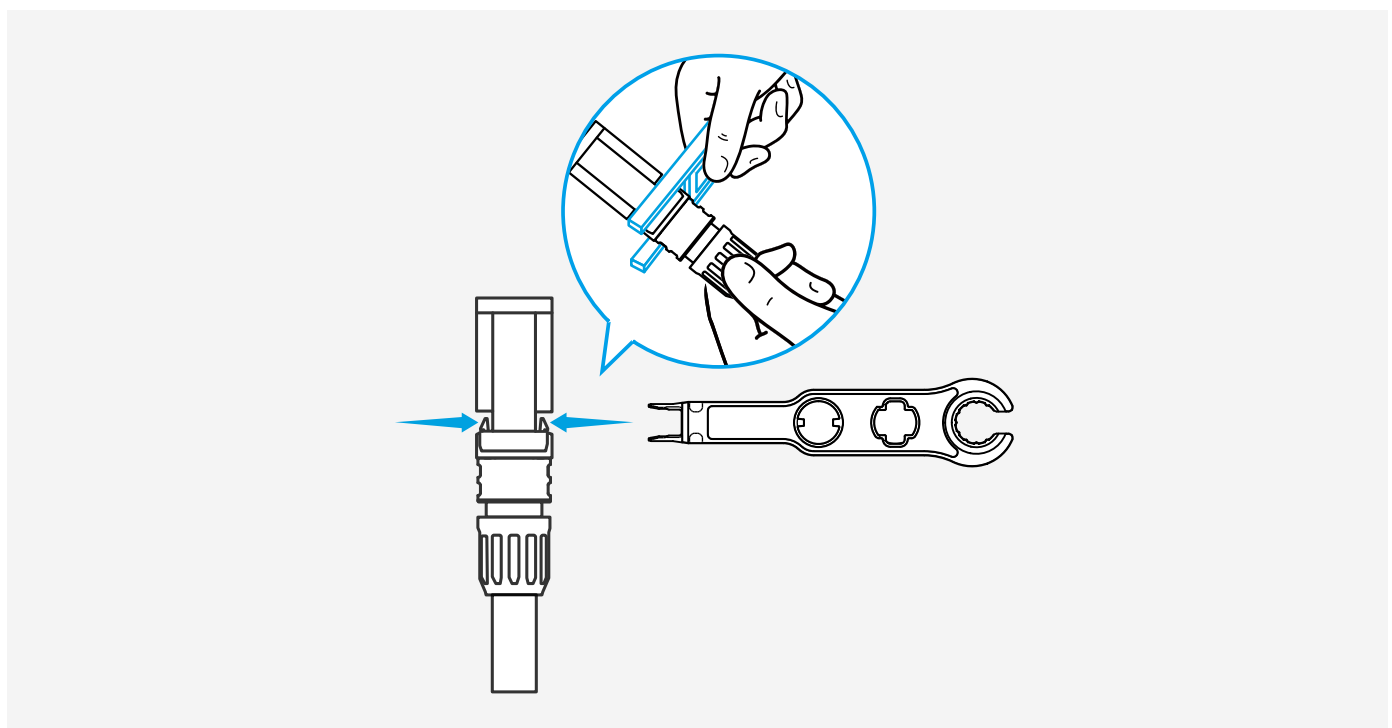

(Optional) Install the Smart Meter

Solarbank can be used with Anker SOLIX Smart Meter. For installation instructions, please refer to [Anker SOLIX Smart Meter User Guide \(A17X7\)](#).

(Optional) Install the Smart Plug

Solarbank can be used with Anker SOLIX Smart Plug. For installation instructions, please refer to [Anker SOLIX Smart Plug User Guide \(A17X8\)](#).

Device Setup

Power On / Off

The first use requires connections to both a PV module and a home outlet.

- **With solar or AC input:** Solarbank turns on automatically. To turn it off, disconnect it from both the PV modules and the home outlet, and then press the power button for 3 seconds.
- **Without solar and AC input:** Press the power button for 3 seconds to turn Solarbank on or off.

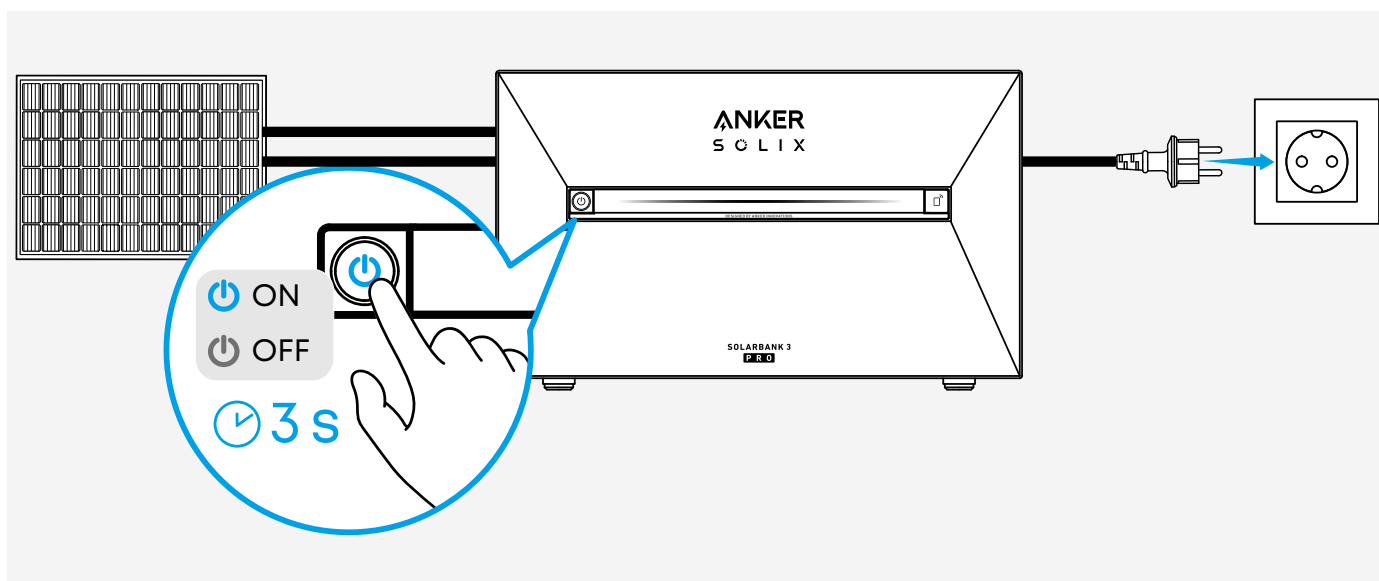

Confirm Networking Status

Solarbank enters networking mode automatically when powered on. Confirm that the IoT button is flashing blue.

💡 If the initial network connection is not completed within 30 minutes and there is no solar and AC input available, Solarbank will automatically shut off.

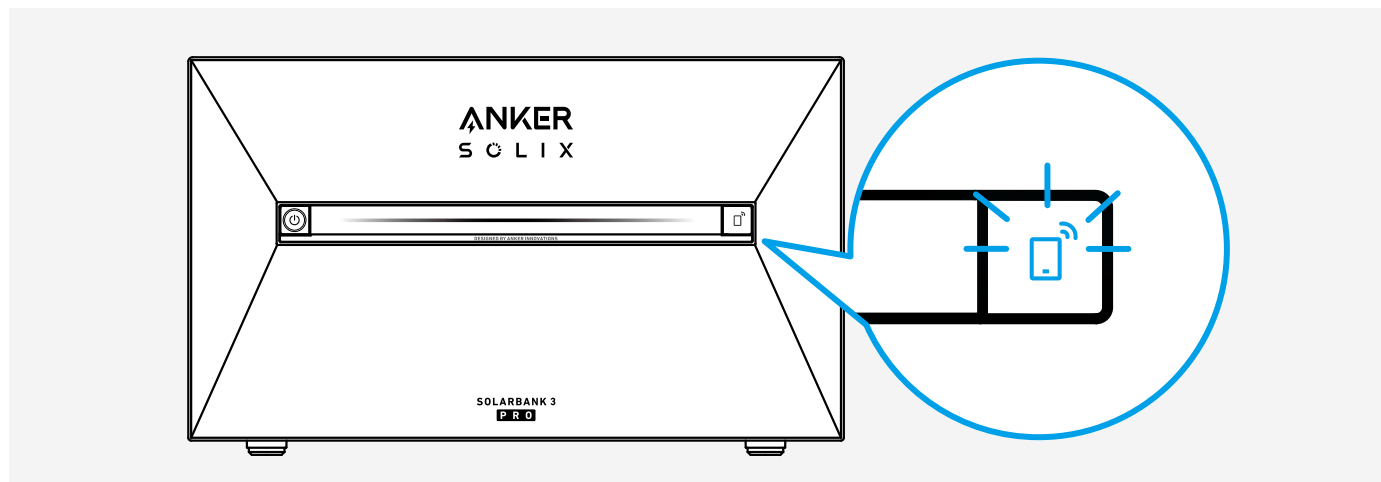

Use the Anker App

The Anker App allows you to monitor and manage your Solarbank system easily. Please note that the user interface images displayed are for illustration purposes and may differ from your actual view based on the software version.

Download the Anker App

Download the Anker app from the App Store (iOS devices) or Google Play (Android devices), or by scanning the QR code.

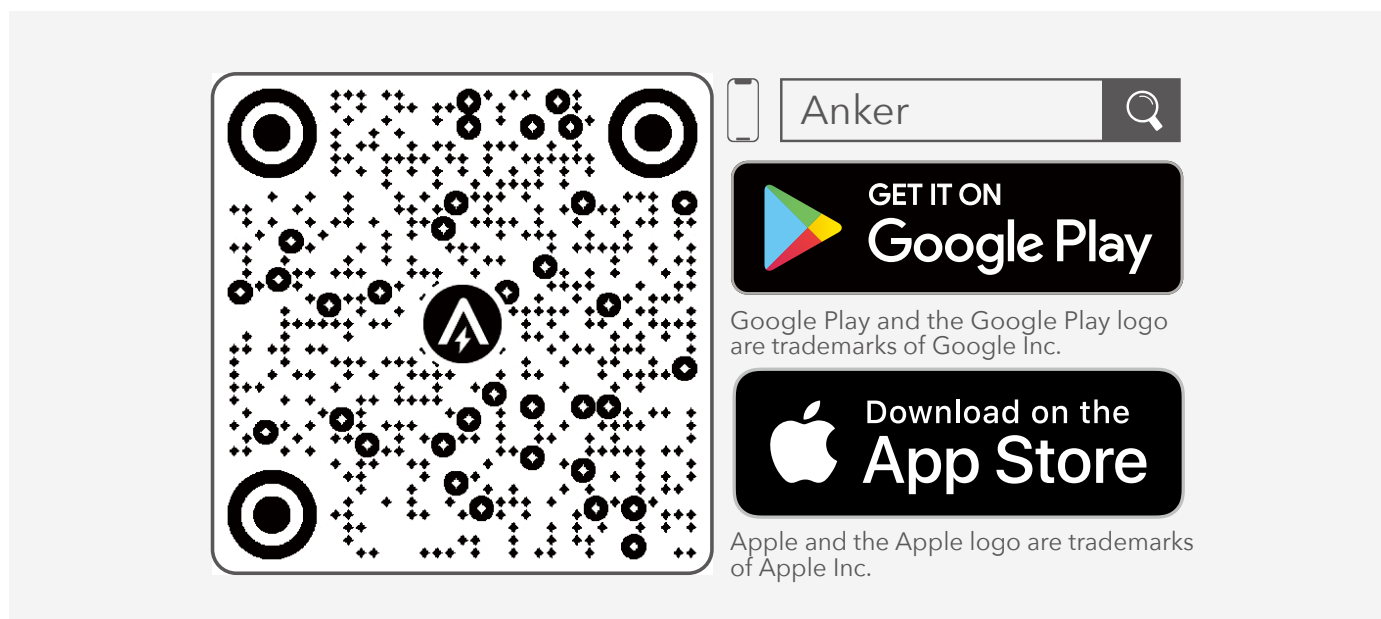

Sign Up / Sign In

Sign in or create an account. Please be reminded that the country or region MUST match where you live. An incorrect country or region may cause the device connection to fail.

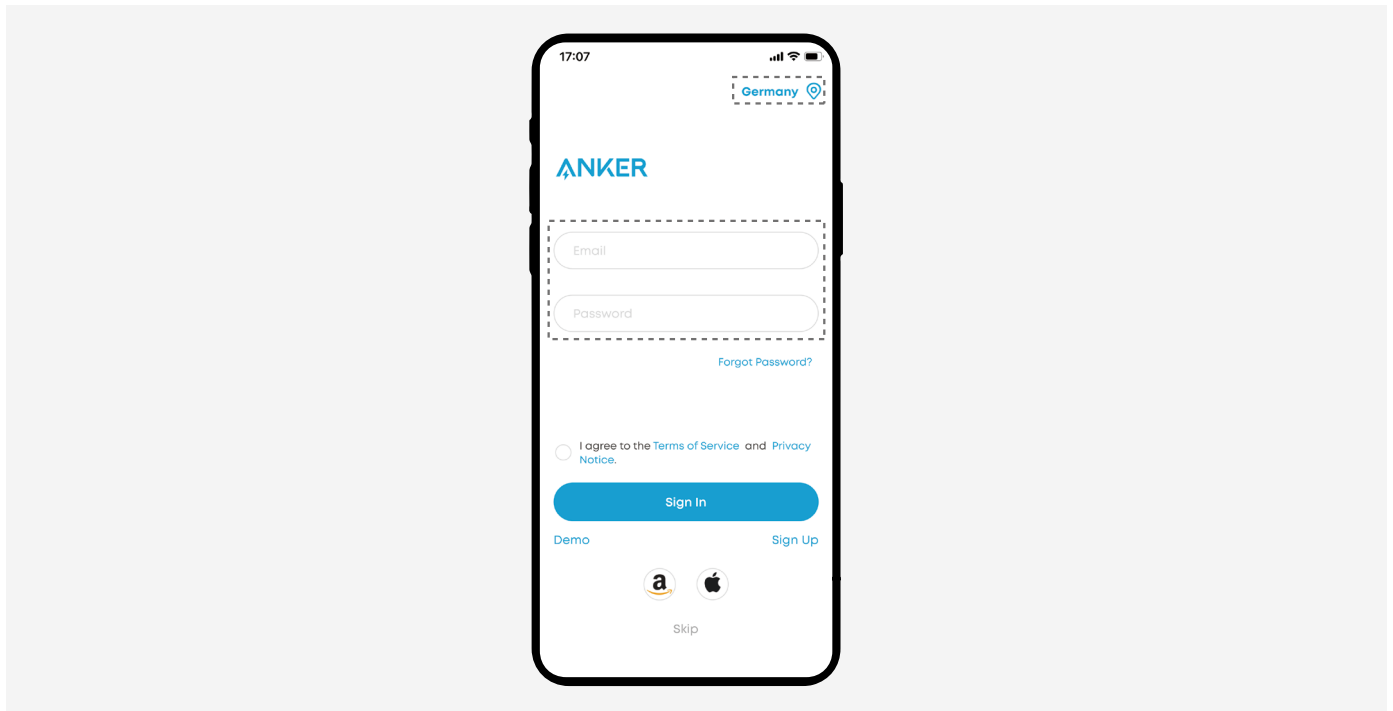

Connect to the Network

Add your Solarbank and connect it to your Wi-Fi network.

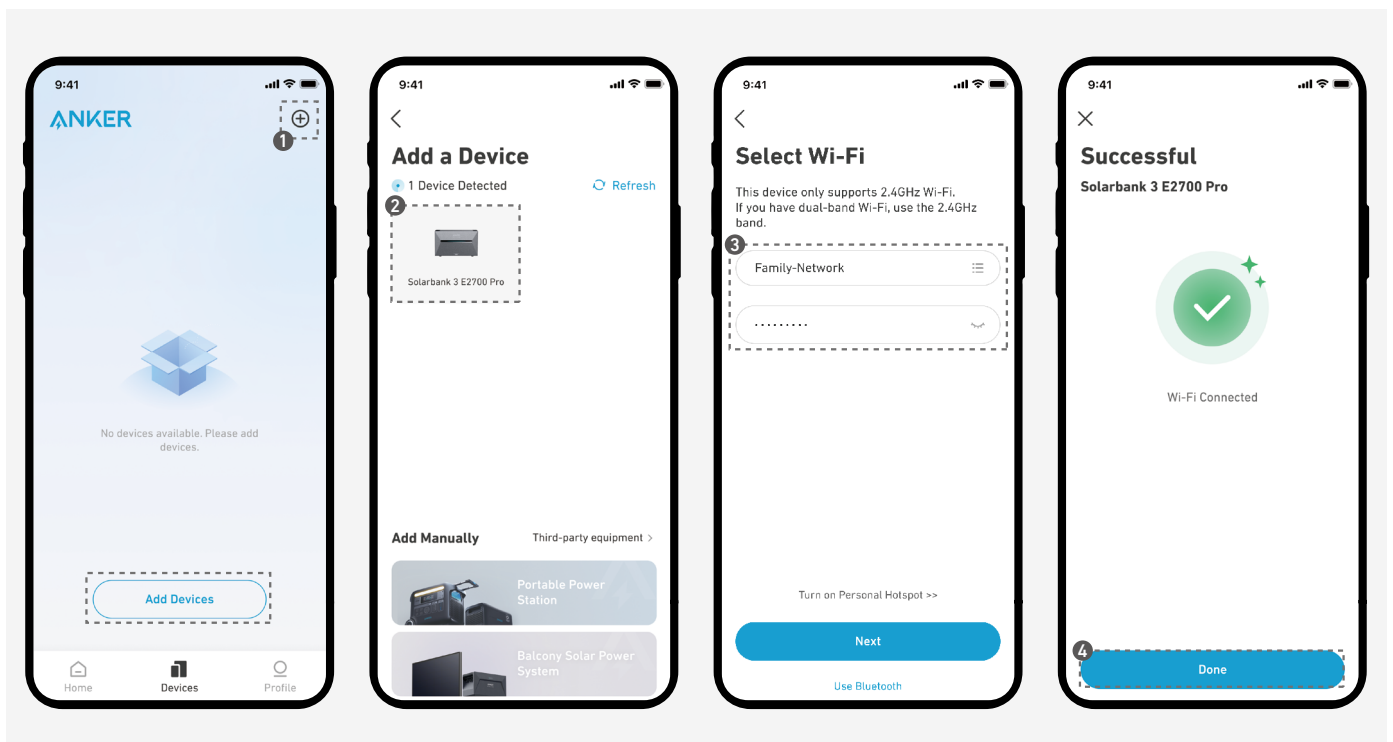

If you encounter connection issues, try the following:



- Confirm that your Wi-Fi router is working normally.
- Move your router closer to Solarbank.
- Verify that the Wi-Fi password is correct.

Add Home Devices

You can add other devices to interact with your Solarbank.

If the device has been bound to your account, simply select it from the list. Otherwise, tap **Add Devices** to bind new devices and complete the network connection.

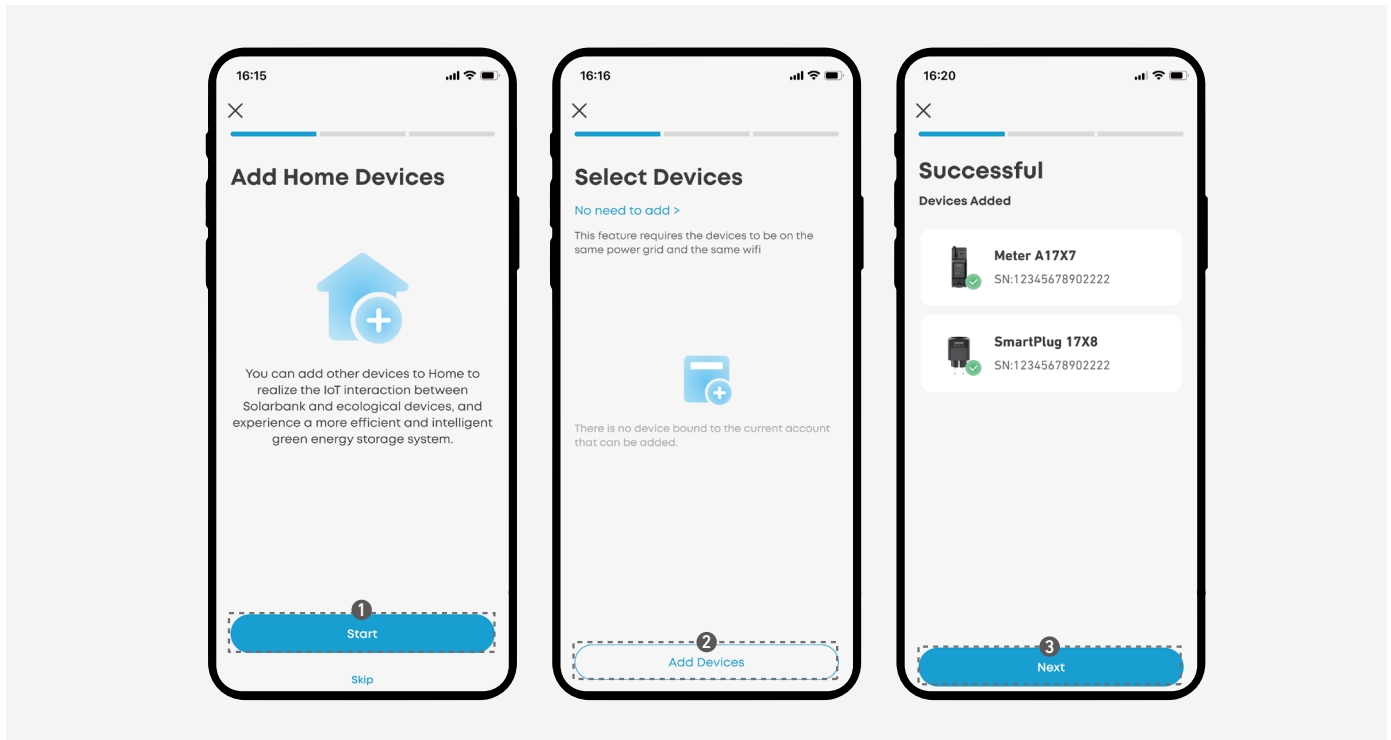

Upgrade Firmware

Regularly upgrade the firmware to enjoy optimal performance.



- Before upgrading, ensure all devices are connected to a stable Wi-Fi network.
- The upgrade process may take a few minutes. Please be patient.
- If the upgrade fails, check if the devices are turned on and connected to Wi-Fi.

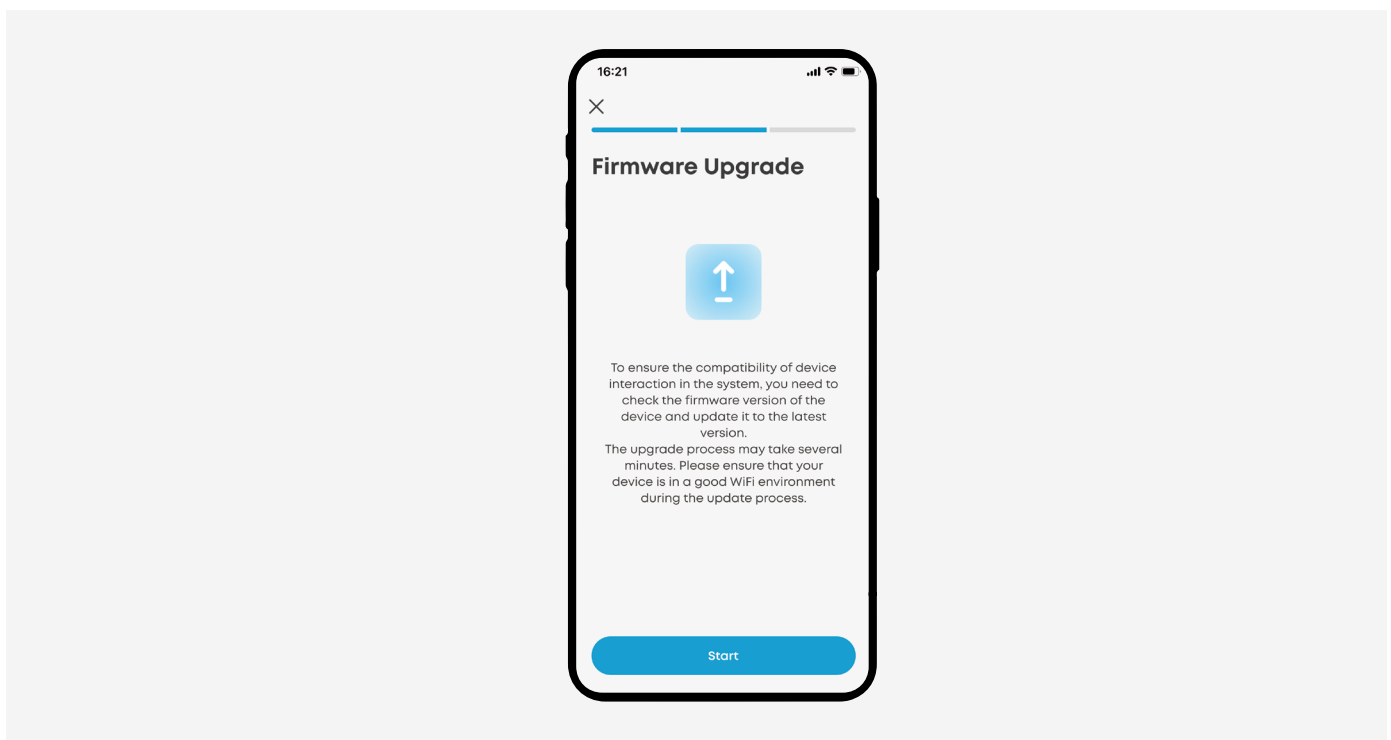

Customize Power Mode

Choose how your Solarbank manages power through the following modes to meet your home's energy needs.

Access Mode Selection

During Setup: Select a power mode from the options provided.

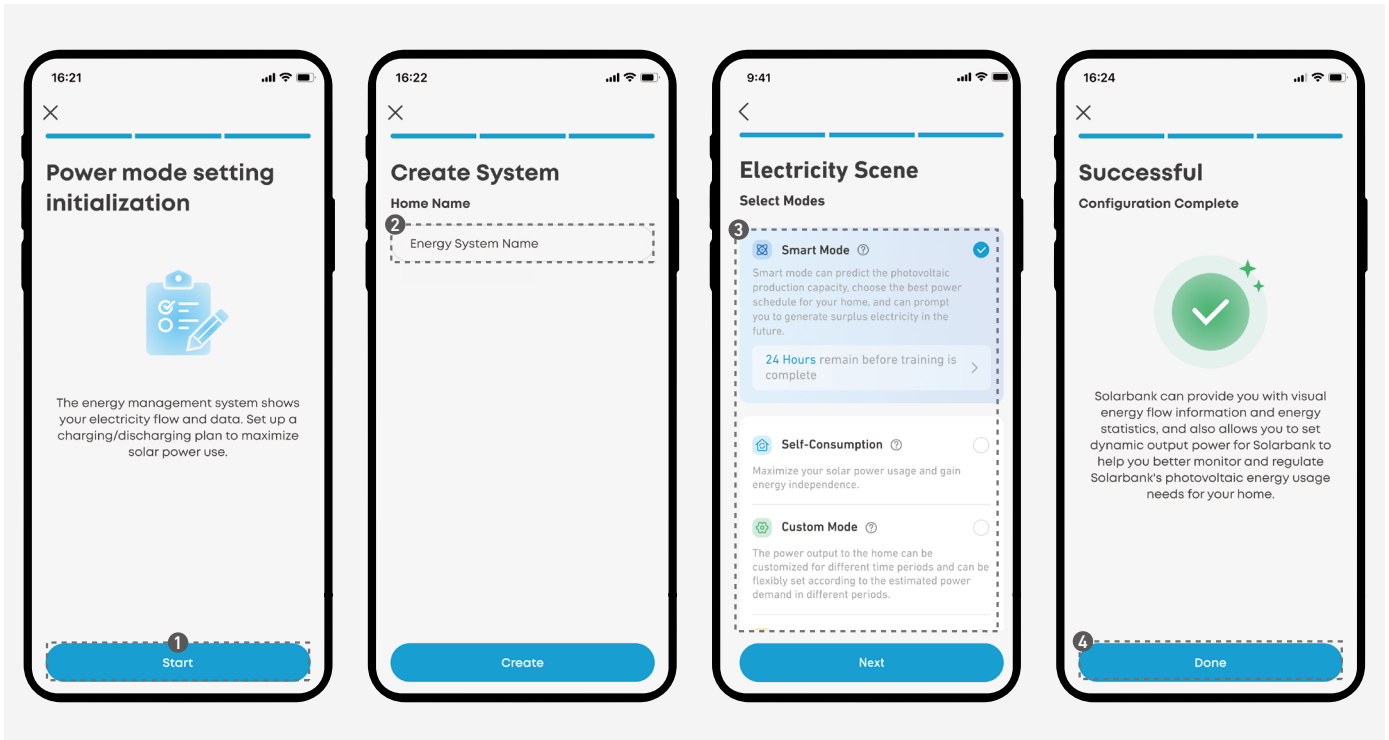

After Setup: Access mode selection from the shortcut on the home page.

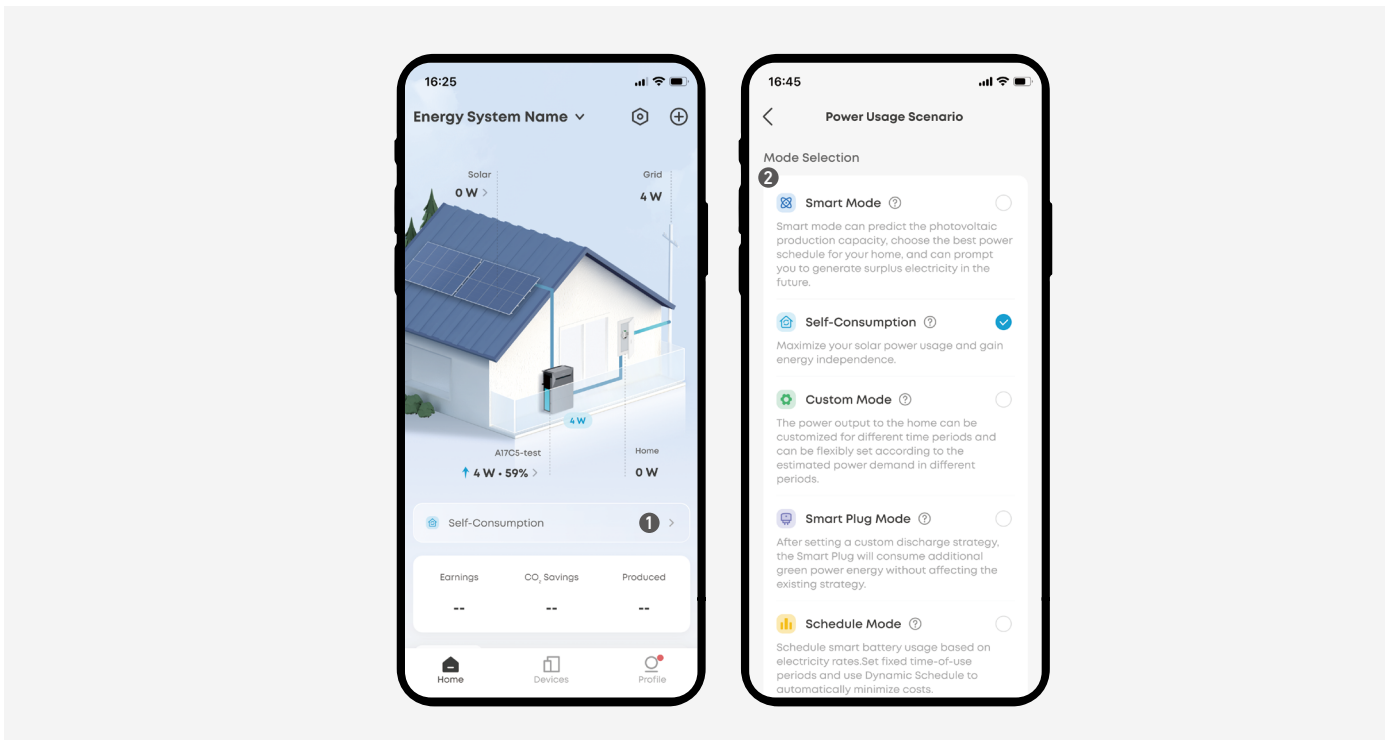

Smart Mode

In smart mode, your Solarbank forecasts future electricity production and consumption, as well as electricity prices, to create an optimal power schedule.

💡 Smart mode requires a smart meter and is only compatible with phones that support Google Maps.

How to Set Up:

1. Select **Smart Mode**.
2. Complete the following settings:
 - Add a smart meter.
 - Authorize data access.
 - Authorize location access.
 - Set your utility rate plan.
 - (Optional) Add and set your power plug.
3. Solarbank will start self-learning and complete it within a maximum of 24 hours.

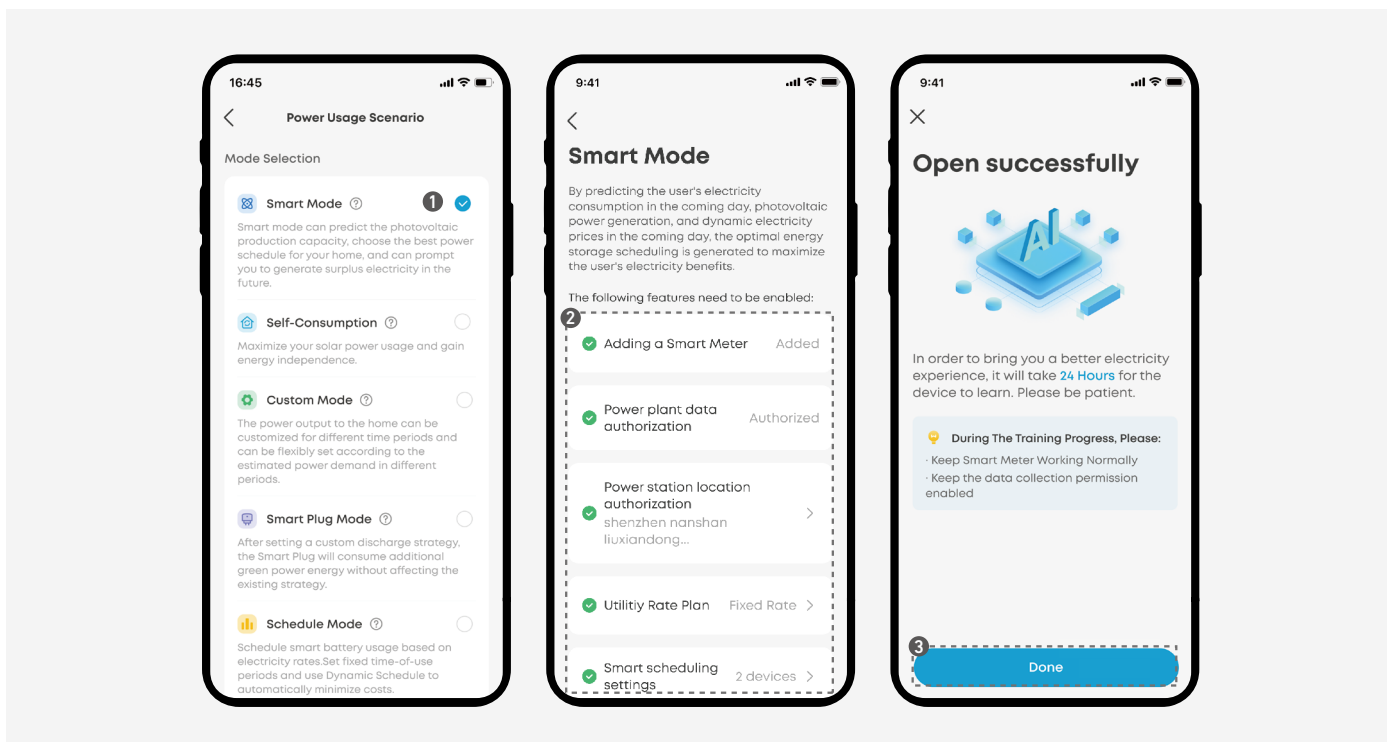

Self-Consumption Mode

Self-consumption mode maximizes your use of solar power and minimizes reliance on the grid. In this mode, the smart meter will continuously monitor power demand and Solarbank will dynamically adjust the power output or storage.



- Self-consumption mode requires a smart meter.
- If the smart meter goes offline or malfunctions, Solarbank will automatically switch to custom mode until the smart meter is functional again.

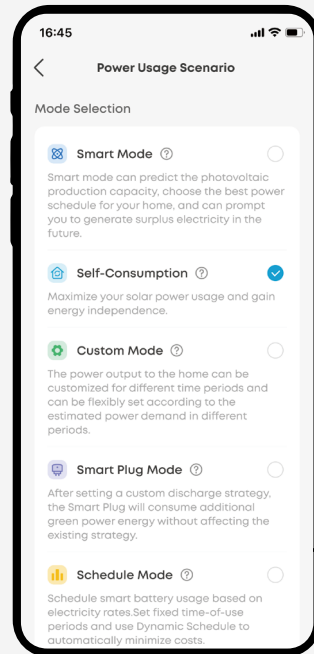

Custom Mode

Customize power output based on your specific needs throughout the day. In this mode, you can set a 24/7 schedule of photovoltaics consumption and storage for the Solarbank system. The system will power your home loads according to the schedule you set.

How to Set Up:

1. Select **Custom Mode** and tap **Setting**.
2. Tap **+** to add an energy plan.
3. Tap **Set a Schedule** to set discharge schedules for household loads.
4. Tap **Repeat** for other weeks as needed.
5. Save and apply the energy plan by tapping **✓**.

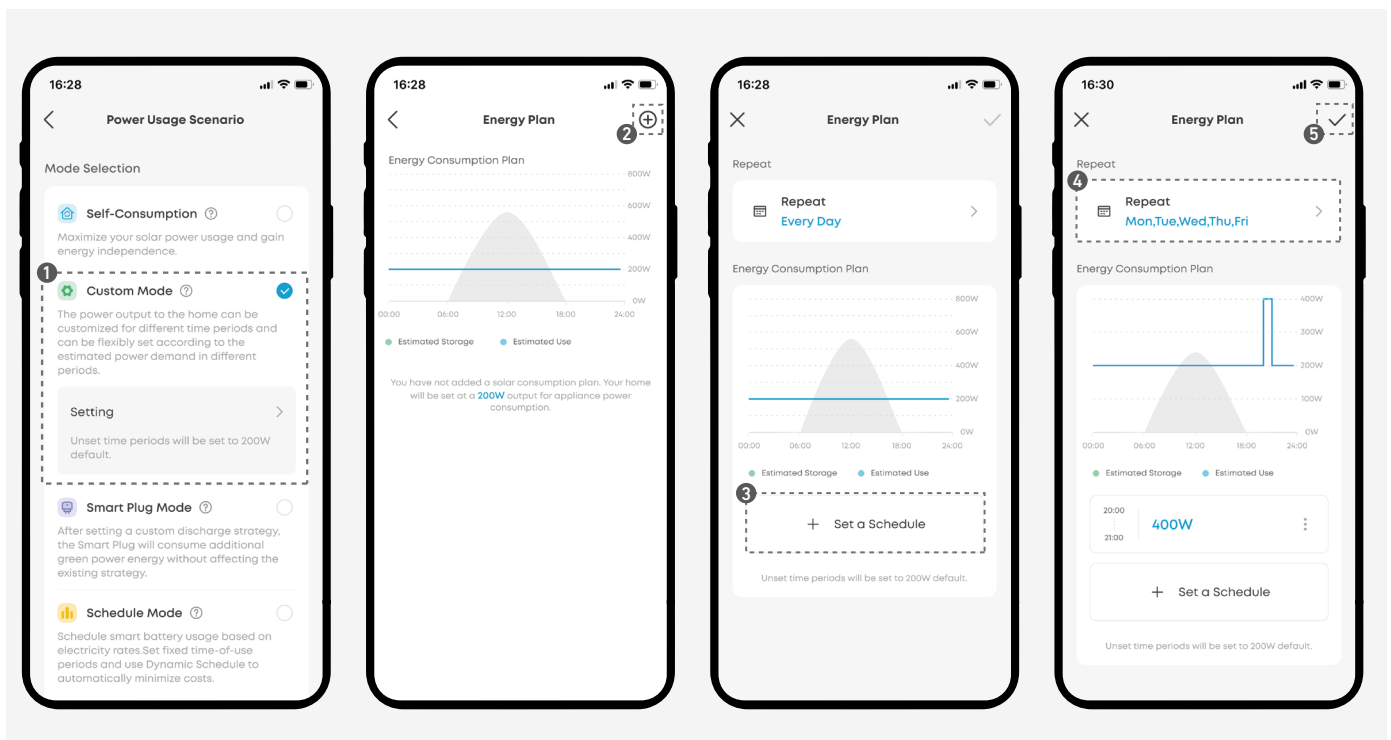

Smart Plug Mode

After a custom discharge strategy is set, the smart plug will consume additional green power energy without affecting the existing strategy.

In this mode, you can set a 24/7 schedule of photovoltaics consumption and storage for the Solarbank system. When the smart plug has power demand, it will be given priority, and then power will be supplied to the household load according to the schedule you set.

💡 Smart plug mode requires at least one smart plug. Up to 5 smart plugs can be added.

How to Set Up:

1. Select **Smart Plug Mode** and tap **Setting**.
2. Tap **+** to add an energy plan.
3. Tap **Set a Schedule** to set discharge schedules for household loads.
4. Tap **Repeat** for other weeks as needed.
5. Save and apply the energy plan by tapping **✓**.

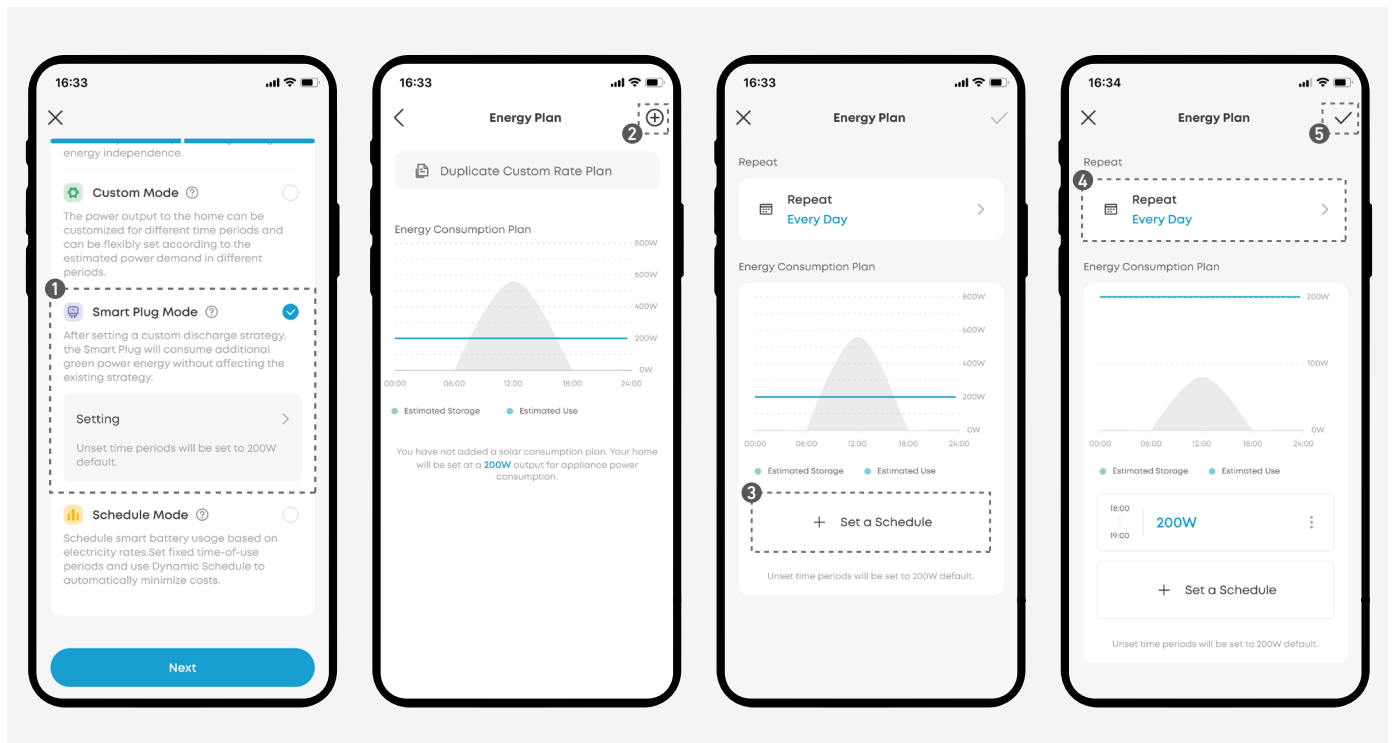

Schedule Mode

Schedule smart battery usage based on electricity rates. Set fixed time-of-use periods and use the dynamic schedule to automatically minimize costs. Distribute household energy use according to peaks and troughs that you set.

💡 Schedule mode requires a smart meter.

Time of Use	<p>Manually set the charge and discharge intervals to schedule energy use throughout the day. The periods are categorized as follows:</p> <ul style="list-style-type: none">• Off-Peak: Photovoltaic power prioritizes supplying the load. Excess electricity recharges energy storage. If photovoltaic power is insufficient, energy storage supplies power to the load until remaining power is approximately 80%.• Super Off-Peak: Photovoltaic power prioritizes recharging energy storage. If power generation is insufficient, electricity will be purchased from the grid. When energy storage is fully charged, the load will be powered by photovoltaic energy and grid electricity. Energy storage will not discharge at all during this time.• Peak / Mid-Peak: Photovoltaic power prioritizes supplying the load. Excess photovoltaic power recharges energy storage. If photovoltaic power is insufficient for the load, energy storage will discharge and power will be purchased from the grid to meet demand.
Time Slot	Auto-schedule battery charging and discharging based on dynamic electricity rates for maximum savings.

How to Set Up Time-of-Use Mode:

1. Select **Schedule Mode**.
2. Tap **Time-of-Use**.
3. Choose either **Seasons** or **Year-Long** based on your rate structure.
 - If using **Year-Long**, proceed to the next step.
 - If using **Seasons**, set your season with the handles. You can add or remove seasons using the **+** or **-**.
4. Edit time periods by dragging the slider. Tap **Add Period** to include additional periods. Repeat this for other seasons if necessary.
5. Enter the rate pricing. Set unique "buy" and "sell" prices for each time period.
6. Repeat steps 4 and 5 for all time periods and seasons.
7. Review and save your settings.

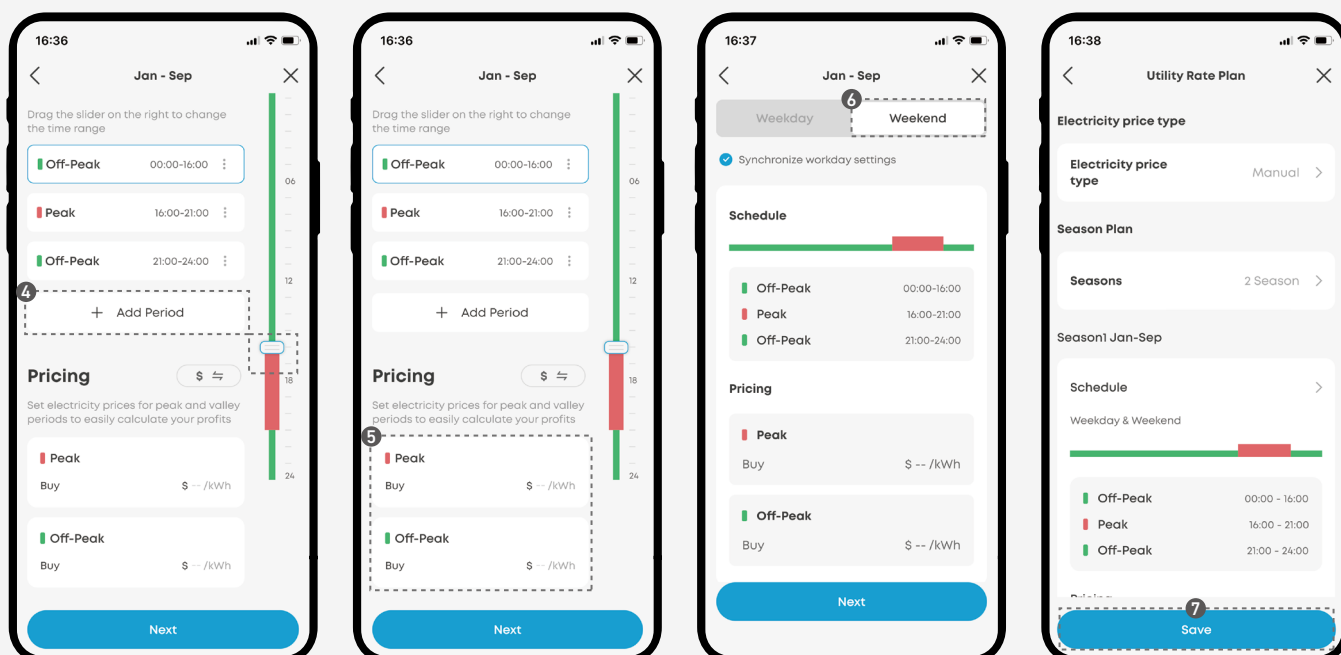
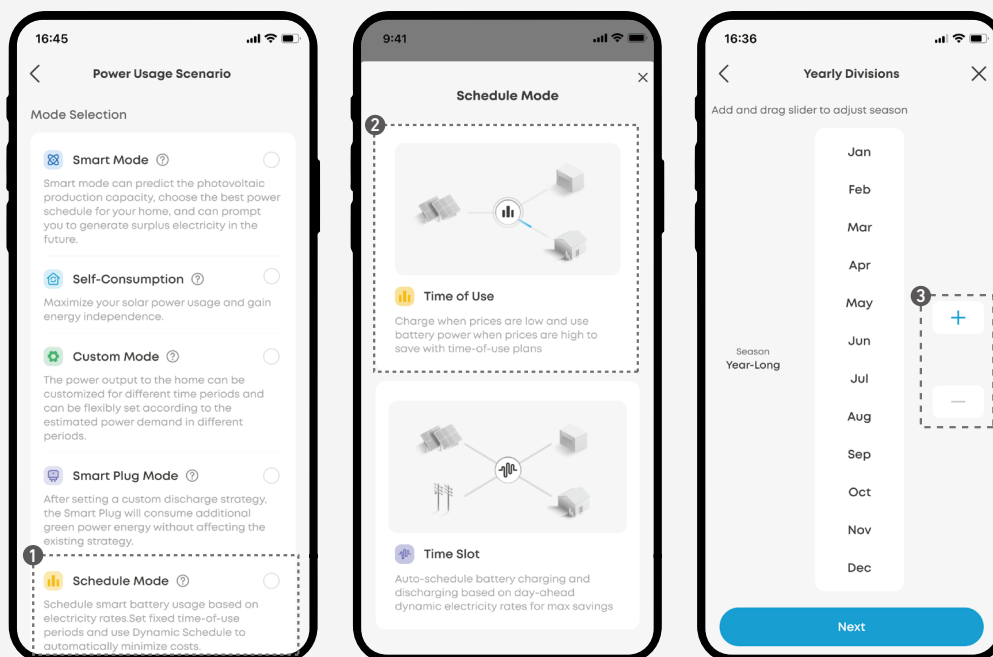

How to Set Up Time Slot Mode:

1. Select **Schedule Mode**.
2. Tap **Time Slot**.
3. Select Nordpool as the electricity price data provider and choose your region.
4. Review and modify the purchase price and selling price (if applicable) as needed.

Purchase Price	<ul style="list-style-type: none">· VAT: Confirm the correct value-added tax rate for your area.· Fee: Ensure it includes other applicable taxes, network fees, and levies.· Note: The combined total of the wholesale price, VAT, and fees should closely match the retail price on your electricity bill.
Selling Price (If Applicable)	<ul style="list-style-type: none">· Tariff Type: If you intend to sell energy to the grid, select the appropriate tariff type.· Fee: Set the selling price accordingly.

5. Check time slot settings and make adjustments as needed.

The system determines the optimal charging and discharging time slots based on the electricity prices and your settings.

Charging and Discharging Available Period	You can set the time period for charging and discharging. During the time period, the system will execute the EMS schedule according to the charging operation times and discharging operation times set below.
Charging Settings	<ul style="list-style-type: none">· Cutoff Power: The system automatically stops charging when the battery reaches the cutoff power.· Charging Operation Times: The system will identify the corresponding periods with lowest electricity prices based on your settings, and then automatically charge the battery during those periods.
Discharging Settings	<ul style="list-style-type: none">· Discharging Operation Times: The system will identify the corresponding periods with highest electricity prices based on your settings, and then automatically discharge the battery during those periods.· Excess to Grid: Enable this feature to feed excess energy to the grid. If this feature is disabled, the energy will be reserved for home use.

Notes:

- If the charging or discharging times are not set, the system will execute the self consumption mode.
- If the charging or discharging times is set, the system will charge or discharge within the set time period.

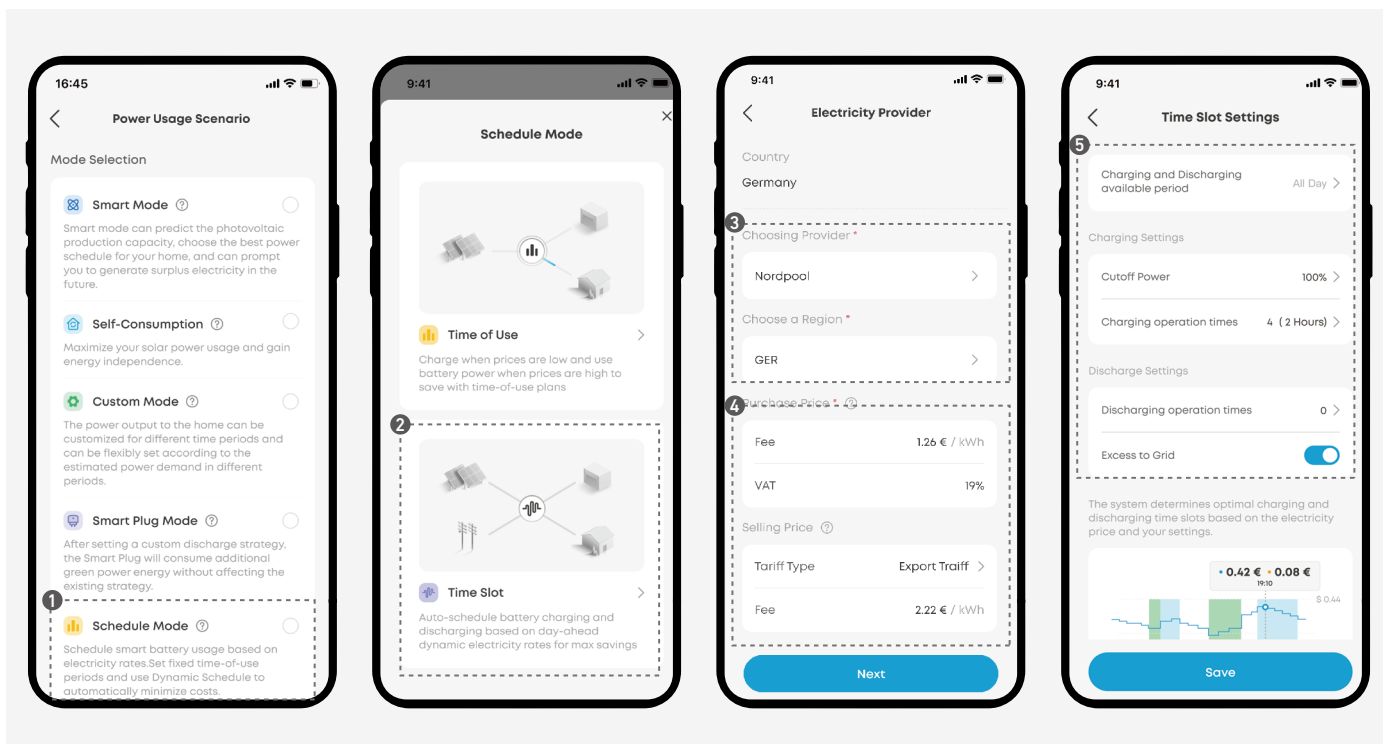

Manual Backup Power

When manual backup power is enabled, Solarbank prioritizes battery charging in case of storm warnings or potential outages. You can set the start and end time for this change.

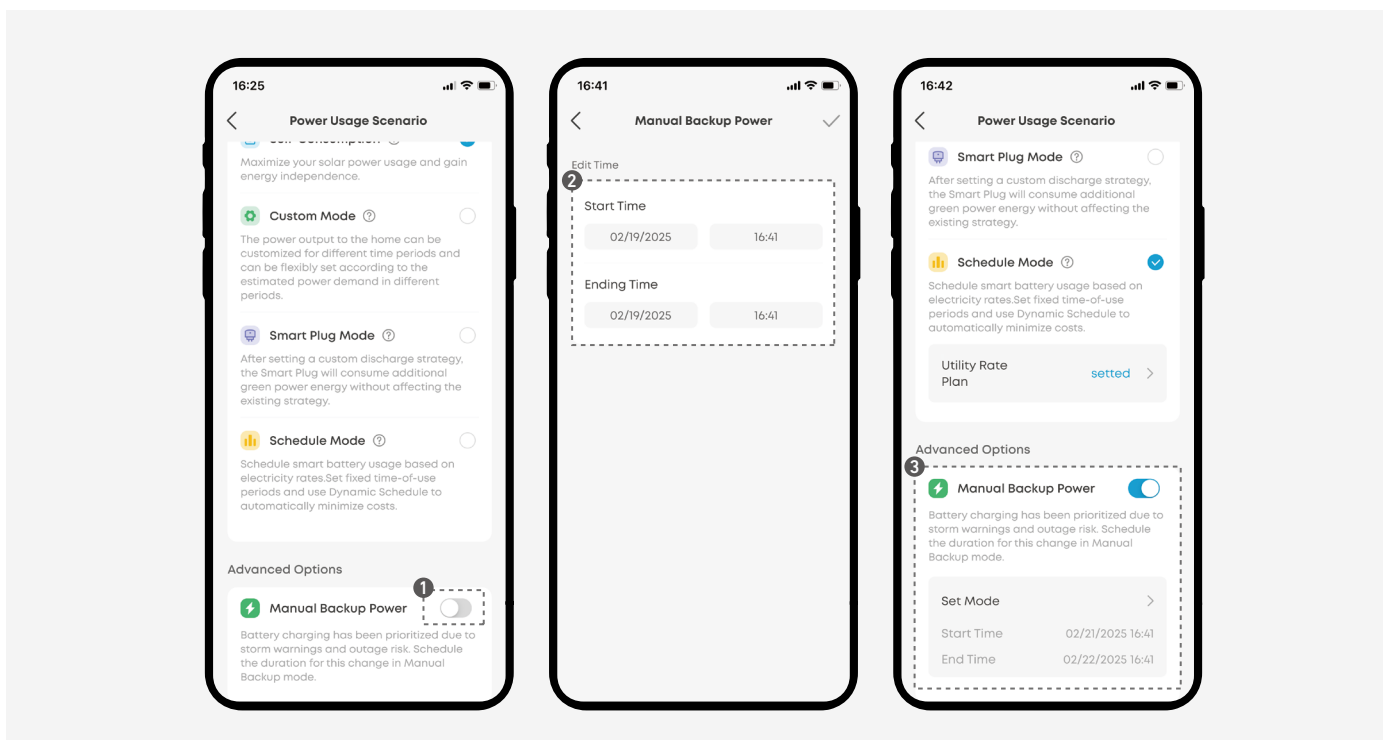

Adding an Expansion Battery

Precautions

- To protect yourself and the equipment, ensure the system is powered off before installing or adding expansion batteries. Installation while the system is powered on is not covered under warranty.

- Follow the steps below to add an expansion battery to the system. The example system includes one Solarbank and two expansion batteries.

Step 1. Disassemble the System

1. Disconnect Solarbank from PV modules.
2. Unplug Solarbank from the home outlet and any connected device.
3. Ensure Solarbank is off. To turn it off, press the power button for 3 seconds.
4. If applicable, remove the L-shape wall mount fittings from both sides of the first expansion battery under Solarbank.
5. If applicable, remove the fixed brackets from both sides of the expansion battery.

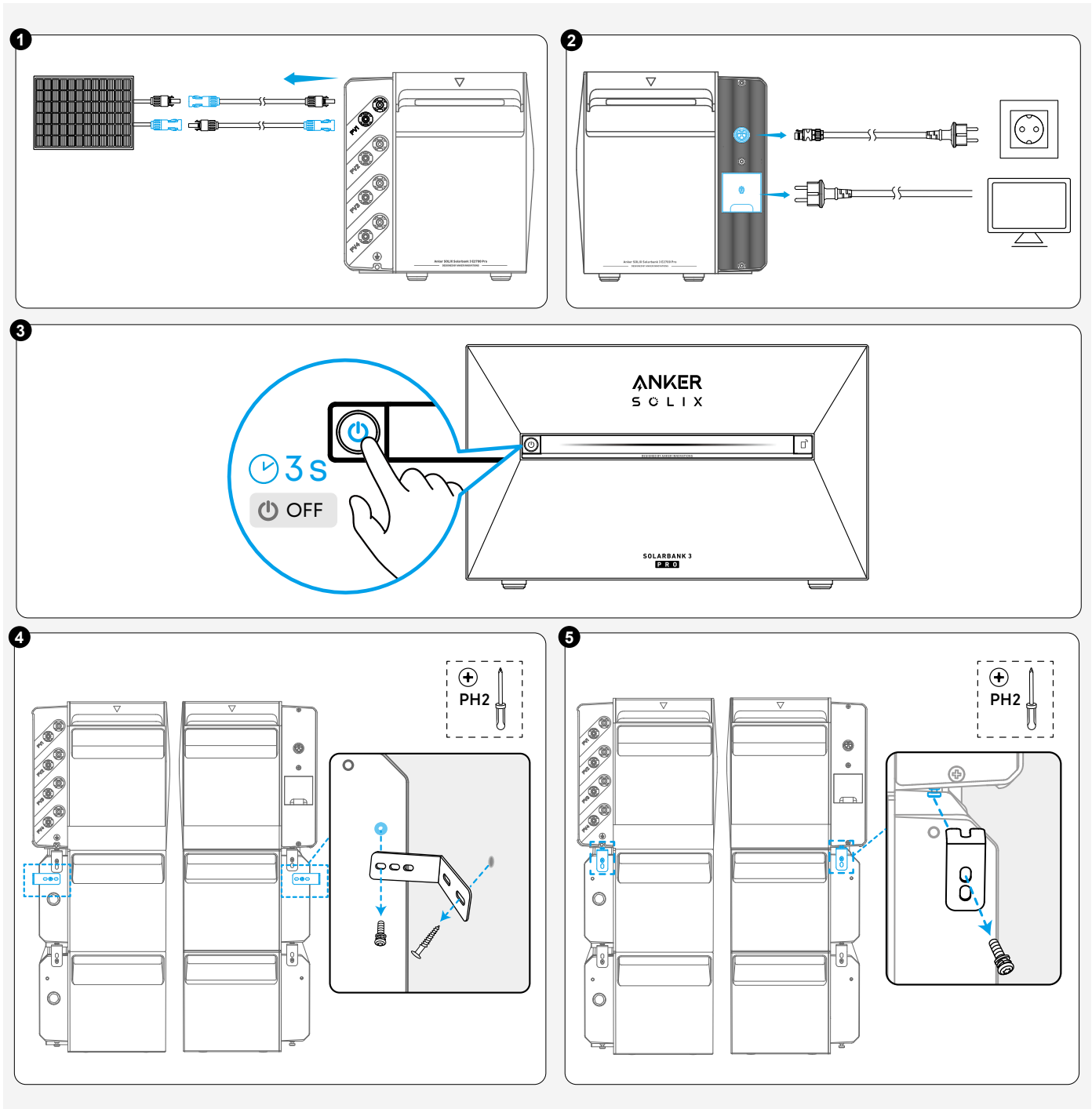

Step 2. Mount the Expansion Battery

1. Unfasten the screws (if applicable) and remove the rubber plugs.
2. Stack the new expansion battery under Solarbank.

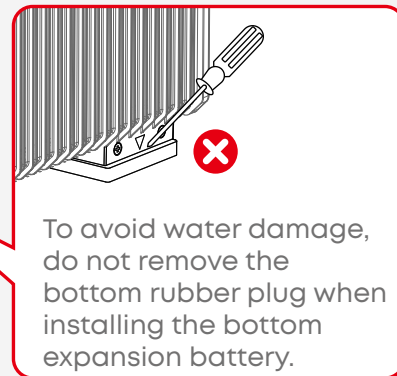
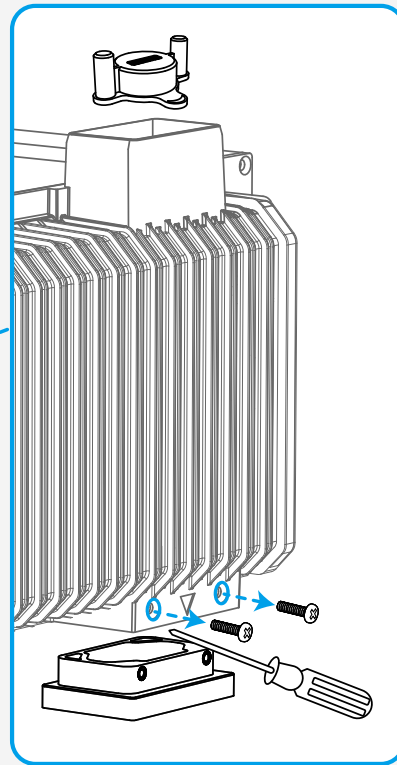
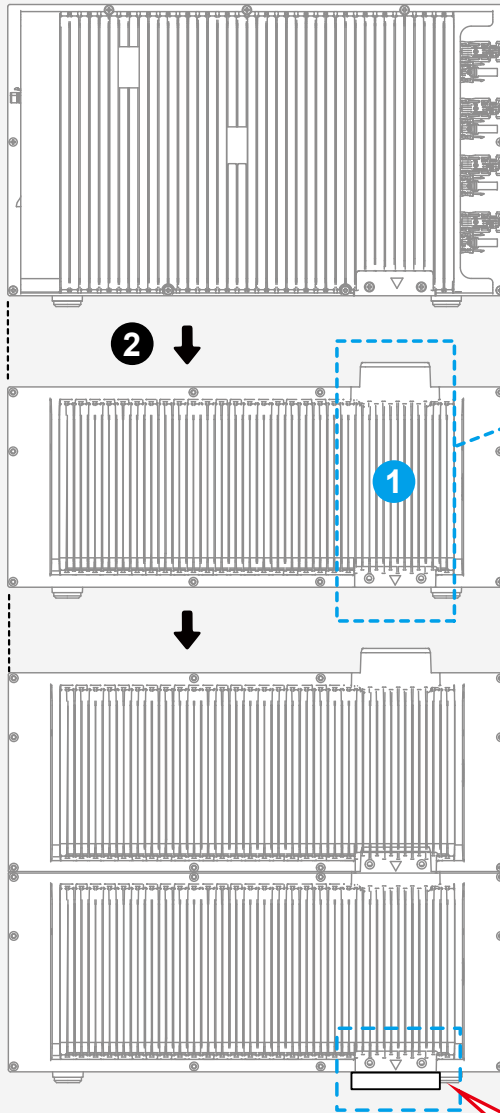
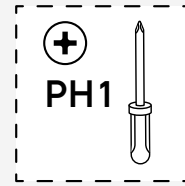

Step 3. Reassemble the System

1. Reinstall the L-shape wall mount fittings on both sides of the first expansion battery under Solarbank.
2. Snap the fixed brackets in place and tighten them to the expansion batteries.
3. Plug Solarbank back into the home outlet and reconnect your device.
4. Reconnect Solarbank and PV modules.
5. If there is solar or AC input, Solarbank will power on automatically. To manually turn it on, press the power button for 3 seconds.

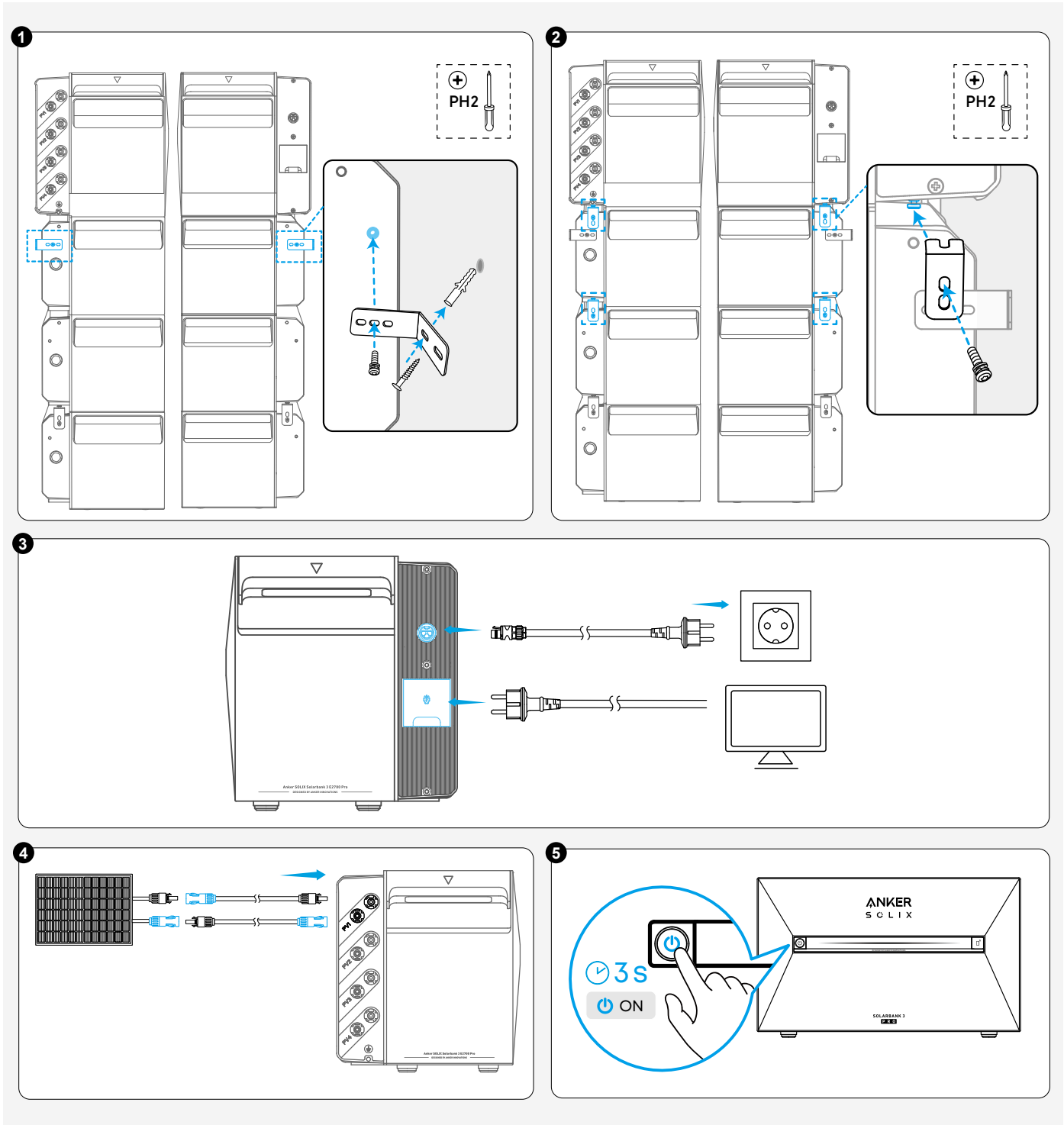

FAQ

1. Q: Are there any other precautions that need to be taken when installing and using the equipment?

A: Ensure the AC outlet is properly grounded.

2. Q: Can PV modules be connected in series?

A: No. Never connect two or more PV modules in series because this causes the input voltage to exceed 60V and will damage the equipment.

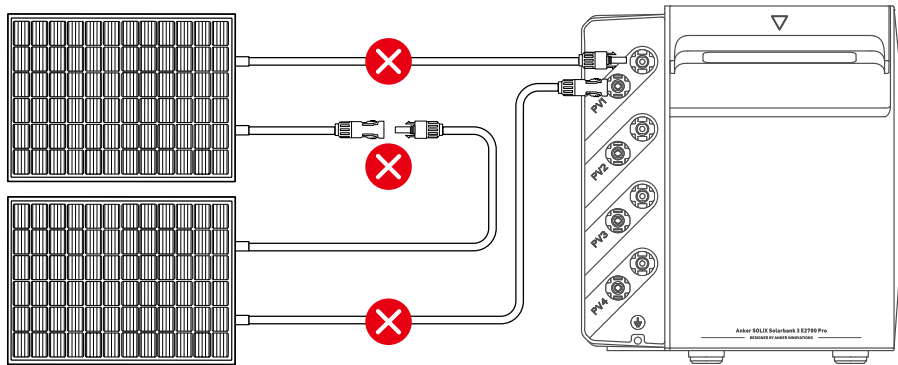

3. Q: Can Anker SOLIX Solarbank 3 E2700 Pro be used with both Anker SOLIX BP1600 Expansion Batteries and Anker SOLIX BP2700 Expansion Batteries at the same time?

A: Yes. Please note the following when using them together:

- The charging power of Anker SOLIX Solarbank 3 E2700 Pro remains unaffected.
- The total maximum charging power of the expansion batteries is limited to 2,000W. (Note: This value can be increased to 3,600W if only Anker SOLIX BP2700 Expansion Batteries are used.)

4. Q: Can I use smart mode if my phone does not support Google Maps?

A: No. Smart mode is only compatible with phones that support Google Maps.

5. Q: How does smart mode work?

A: Smart mode starts with a 24-hour learning period during its first activation. During this time, the system runs in self-consumption mode. It uses AI to analyze your electricity usage, generation, and price changes. This helps the system automatically manage when to charge and discharge, maximizing the use of green energy and low-cost electricity. This ensures optimal power distribution, utilizes excess power effectively, and enhances energy savings.

6. Q: Why did the smart mode learning process fail?

A: Smart mode learns from historical data to determine the best strategies. If the smart meter is disconnected, data is insufficient, or there are significant data fluctuations, the learning process may take longer or fail. Make sure the smart meter is connected, maintain a consistent power usage pattern, and select Continue Learning in the app. The system will finish learning as quickly as possible to activate smart mode functionality.

7. Q: Why are my earnings low in smart mode?

A: Earnings in smart mode come from smart charging and discharging, as well as utilizing excess power. Earnings from smart charging and discharging are more significant on cloudy days or in winter due to less sunlight, while sunny days or summer yield more from excess power usage. Although daily earnings may seem small, they accumulate over time. Be sure to check your total earnings periodically.

8. Q: How do I set up a smart plug to use excess power?

A: Open the Anker app and navigate to the earnings page. Click the icon next to Intelligent Scheduling Days to view scheduling details. Here, you can see excess power information and enable the smart plug to turn on automatically. Make sure you have a smart plug connected to utilize this feature.

9. Q: What devices are suitable for using excess power?

A: You can effectively use excess power by connecting devices to a smart plug. It is recommended to use devices like e-bikes to maximize the benefits of any excess power generated.

Specifications

Specifications are subject to change without notice.

Anker SOLIX Solarbank 3 E2700 Pro

Model	A17C53Z1, A17C53Z1-1, A17C53Z1-2, A17C53Z1-3, A17C53Z1-4, A17C53Z1-5
PV Terminal	
Max PV Input Voltage	60VDC
Max PV Input Current	32ADC ×4
Max Isc PV	40ADC ×4
Max PV Input Power	900W ×4
Operation Voltage Range	16-60VDC
Battery Data	
Rechargeable Li-ion Battery	LiFePO ₄
Battery Nominal Voltage	25.6VDC
Max Charge Current	70ADC
Max Discharge Current	75ADC
Rated Power (Single Device)	1,800W
Rated Energy	2,688Wh
Rated Capacity	105Ah
IEC Code	IFpP52/161/120[8S]M/-20+50/90 (A17C53Z1) IFpP/52/161/120[[8S]2P]/M/20+50/90 (A17C53Z1-1) IFpP/52/161/120[[8S]3P]/M/20+50/90 (A17C53Z1-2) IFpP/52/161/120[[8S]4P]/M/20+50/90 (A17C53Z1-3) IFpP/52/161/120[[8S]5P]/M/20+50/90 (A17C53Z1-4) IFpP/52/161/120[[8S]6P]/M/20+50/90 (A17C53Z1-5)
AC Input (On-Grid Terminal)	
Max AC Input Power	2,000W
Max AC Input Current	10AAC
Max AC Charge Power	1,200W
Max AC Charge Current	5.3AAC

AC Nominal Input Voltage	L + N + PE, 220VAC / 230VAC, 50Hz
AC Output (On-Grid Terminal)	
AC Output Power	800W
Max AC Output Current	3.5AAC
AC Nominal Output Voltage	L + N + PE, 220VAC / 230VAC, 50Hz
Power Factor	0.8 Lagging - 0.8 Leading
AC Output (Off-Grid Terminal)	
Max AC Output Power	1,200W
Max AC Output Current	5.3AAC
Max AC Bypass Output Power	2,000W
Max AC Bypass Output Current	10AAC
AC Nominal Output Voltage	L + N + PE, 220VAC / 230VAC, 50Hz
General Parameters	
Protective Class	Class I
Ingress Protection	IP65
Inverter Topology	Isolated
Operating Temperature Range	-20°C to 55°C
Max Altitude	4,000 m
Warranty	10 Years
Dimensions	460 × 254 × 279 mm
Net Weight	29.2 kg

Model	A17C53Z1-20, A17C53Z1-20-1, A17C53Z1-20-2, A17C53Z1-20-3, A17C53Z1-20-4, A17C53Z1-20-5
PV Terminal	
Max PV Input Voltage	60VDC
Max PV Input Current	32ADC ×4
Max Isc PV	40ADC ×4
Max PV Input Power	900W ×4
Operation Voltage Range	16-60VDC
Battery Data	
Rechargeable Li-ion Battery	LiFePO ₄
Battery Nominal Voltage	25.6VDC
Max Charge Current	70ADC
Max Discharge Current	75ADC
Rated Power (Single Device)	1,800W
Rated Energy	2,688Wh
Rated Capacity	105Ah
IEC Code	IFpP52/161/120[8S]M/-20+50/90 (A17C53Z1-20) IFpP/52/161/120[[8S]2P]/M/20+50/90 (A17C53Z1-20-1) IFpP/52/161/120[[8S]3P]/M/20+50/90 (A17C53Z1-20-2) IFpP/52/161/120[[8S]4P]/M/20+50/90 (A17C53Z1-20-3) IFpP/52/161/120[[8S]5P]/M/20+50/90 (A17C53Z1-20-4) IFpP/52/161/120[[8S]6P]/M/20+50/90 (A17C53Z1-20-5)
AC Input (On-Grid Terminal)	
Max AC Input Power	2,000W
Max AC Input Current	10AAC
Max AC Charge Power	1,200W
Max AC Charge Current	5.3AAC

AC Nominal Input Voltage	L + N + PE, 220VAC / 230VAC, 50Hz
AC Output (On-Grid Terminal)	
AC Output Power	1,200W
Max AC Apparent Power	1,200VA
Max AC Output Current	5.3AAC
Rated AC Output Power	800W
Rated AC Apparent Power	800VA
Rated AC Output Current	3.5AAC
AC Nominal Output Voltage	L + N + PE, 220VAC / 230VAC, 50Hz
Power Factor	0.8 Lagging - 0.8 Leading
AC Output (Off-Grid Terminal)	
Max AC Output Power	1,200W
Max AC Output Current	5.3AAC
Max AC Bypass Output Power	2,000W
Max AC Bypass Output Current	10AAC
AC Nominal Output Voltage	L + N + PE, 220VAC / 230VAC, 50Hz
General Parameters	
Protective Class	Class I
Ingress Protection	IP65
Inverter Topology	Isolated
Operating Temperature Range	-20°C to 55°C
Max Altitude	4,000 m
Warranty	10 Years
Dimensions	460 × 254 × 279 mm
Net Weight	29.2 kg

💡 Note:

- The on-grid terminal is also labeled as the grid-tied terminal on the Solarbank package.
- The **1,200W** on the package indicates the AC output power of Solarbank.
- The **2,688Wh** on the package indicates the rated battery energy of Solarbank.

Anker SOLIX BP2700 Expansion Battery

Model	A17C53Z1-85
Battery Data	
Rechargeable Li-ion Battery	LiFePO4
Battery Nominal Voltage	25.6VDC
Max Charge Current	70ADC
Max Discharge Current	75ADC
Rated Power (Single Device)	1,800W
Rated Energy	2,688Wh
Rated Capacity	105Ah
IEC Code	IFpP52/161/120[8S]M/-20+50/90
General Parameters	
Ingress Protection	IP65
Operating Temperature Range	-20°C to 55°C
Max Altitude	4,000 m
Warranty	10 Years
Dimensions	460 × 233 × 217.5 mm
Net Weight	24 kg

Network Configuration Instructions

Bluetooth Low Energy (BLE) Status: When the equipment is not yet connected to a network, it will automatically enable BLE broadcasting and activate BLE services to provide Bluetooth network configuration capabilities.

Note: During the BLE configuration process, ensure your network environment is stable and follow the instructions to complete the setup.

Port 5353

The primary function of port 5353 (TCP/UDP 5353) in a network is to implement the mDNS protocol for mutual discovery between devices on the local area network (LAN).

Application Scenarios: Multi-device linkage, self-consumption scenarios, and energy scheduling strategies in the LAN.

Access the device via `hostname.local` on the same local area network without traditional DNS configuration.

mDNS Protocol Characteristics: Using UDP protocol, port 5353 is its standard port, compatible with the standard DNS query format.